

ASSEMBLY INSTRUCTIONS

FKF 200 / 240 / 270 CONSOLE



SOLARE KOMPETENZ
AUS SACHSEN

Table of contents

Contents	Page
Safety regulations, instructions and guidelines	3
Tools	5
Product description	6
Collector field dimensions	8
Hydraulic connections	10
Bottom support dimensions	11
Assembly bottom support on concrete block	13
Assembly bottom support with fixed dowel	14
Assembly collectors	15
Assembly temperature sensor base console	17
Assembly base console on roof profile	18
Spacing roof hooks	19
Assembly roof-tile clamps	20
Assembly roof-tile clamps with lead cloth	22
Assembly roof-tile clamps plain tile	24
Assembly roof-tile clamps plain tile with lead cloth	25
Assembly roof-tile clamps for corrugated sheet	27
Assembly fastening profiles / console	28
Assembly wall console	30
Assembly temperature sensor wall console	34
Collector connections	35
Hydraulic connection with manifold	36
Overview hydraulic connections Smart Lock System / accessories	37
Overview hydraulic connections Smart Lock System / accessories aluminium	38
Assembly intermediate plates	39
Assembly of the connecting pipe	40
Pipe dimension of the connecting pipe	41
Initial operation	43
Appendix	47

Please read these instructions carefully before beginning the assembly.

Observe the warnings indicated by this sign:



They warn against dangers or erroneous actions. A disregard of the advices and regulations mentioned in the assembly instruction may result in the invalidation of the warranty claim.

The collectors FKF 200, FKF 240 and FKF 270 are monitored according to the CEN-Keymark programme rules Solarthermal Products and are certified with the registration numbers 011-7S1913/1914/1915 F.

The copyright of this instruction incl. graphical material remains property of the STI GmbH. The instruction can only be duplicated completely or in parts with written authorisation of the STI GmbH. Subject to technical changes and misprints.

The collectors of the FKF series are marked with the environmental label RAL-UZ-73 for solar collectors („Blauer Engel“). The STI GmbH is obliged to take back the products which are marked with the environmental label RAL-UZ-73 for solar collectors and to consign them for recycling.

Safety regulations, instructions and guidelines

The standards and guidelines applied at the installation location of the collectors have to be considered in the latest release.

Engineer standards and guidelines

- VBG 4 Unfallverhütungsvorschriften Elektrische Anlagen und Betriebsmittel
 - VBG 37 Unfallverhütungsvorschrift Bauarbeiten
 - VBG 74 Leitern und Tritte
 - ZVDH, Regelwerk
 - LBO's Landesbauordnungen der Bundesländer
 - DIN 18299 Allgemeine Regelung für Bauarbeiten jeder Art
 - DIN 18334 Zimmer- und Holzbauarbeiten
 - DIN EN 12828:2013-04 Heizungsanlagen in Gebäuden
 - DIN 18338 Dachdeckungs- und Dachabdichtungsarbeiten
 - DIN 18339 Klempnerarbeiten
 - DIN 18351 Fassadenarbeiten
 - DIN 18360 Metallbauarbeiten, Schlosserarbeiten
 - DIN 18381 Gas-, Wasser- und Abwasserinstallationsanlagen
 - DIN 18451 Gerüstarbeiten
 - DIN DIN 1055 – Einwirkungen auf Tragwerke - Teil 2: Bodenkenngrößen
 - DIN EN 1991 Einwirkungen auf Tragwerke Teil 1-7
 - DIN 4708 Teil 3 Zentrale Brauchwassererwärmungsanlagen
 - DIN 4102 Brandverhalten von Baustoffen und Bauteilen
 - DIN 4109 Schallschutz im Hochbau
 - DIN EN 516 Einrichtungen zum Betreten des Daches
 - EN 517 Sicherheitsdachhaken
 - DIN 4753 Teil 1 Wassererwärmer und Wassererwärmungsanlagen für Trink- und Betriebswasser; Anforderungen, Kennzeichnung, Ausrüstung und Prüfung
- Teil 2: Sonnenheizungsanlagen mit organischen Wärmeträgern; Anforderungen an die sicherheitstechnische Ausrüstung
- DIN VDE 0100-510 Errichten von Starkstromanlagen mit Nennspannungen bis 1000 V; Allgemeine Bestimmungen
 - DIN VDE 0100-737 Errichten von Niederspannungsanlagen - Feuchte und nasse Bereiche und Räume und Anlagen im Freien
 - DIN EN 62305-1; VDE 0185-305 Blitzschutz
 - DIN VDE 0105-100 Betrieb von elektrischen Anlagen
 - DIN EN 12976: Thermische Solaranlagen und ihre Bauteile (vorgefertigte Anlagen)
 - DIN EN 12977: Thermische Solaranlagen und ihre Bauteile (kundenspezifisch gefertigte Anlagen)
 - DIN 1988: Technische Regeln für Trinkwasser-Installation



Notes prior to the installation start

The installation and initial operation must be carried out by an expert who is responsible for the correct installation and operation. Before installing and putting the collectors into service, please inform about the local engineer standards and regulations.

Components of the collectors can reach temperatures of more than

200 °C, there is a danger of burning and scalding! Furthermore it has to be checked whether there are any load sources in the area of the collector field which may produce chemically aggressive mediums. In condensate dissolved acids and bases may cause permanent damage to the collector components.

Throughout the installation of a solar collector you directly intervene into an existing roof cladding. Different roof coverings such as tile, shingles or slate require additional measures (e. g. sarkings) as a security against the ingress of moisture due to rain or snow - especially in case of extended and occupied top floors or in case of insufficient roof pitches (concerning the covering).

Information on foliation



If the collectors are mounted with foil, this foil must be removed from the collectors at the latest 3 months after delivery. After that, residue-free removal can no longer be guaranteed. The date of the delivery note counts.

Safety regulations, instructions and guidelines

The substructure as well as its connections to the building have to be checked on site according to the local regulations.

The collectors have to be mounted in an angle of at least 20° to max. 70°.

The recommended heat transfer medium is a mixture of glycol and water, e. g. Tyfocor L or similar. The collectors must never be operated or tested with water under pressure.

To protect the system from overheating during standstill and accelerated glycole-ageing, a self-draining system (e. g. STI Drain Master or SolBox) is recommended.

It is necessary to pay attention that the back flow temperature is never lower than the ambient temperature. If necessary, take appropriate action (e. g. increase back flow temperature to at least 30 °C).

To avoid a possible forming of condensate in the collector, the installation has to be taken into operation hydraulically within two weeks after termination of the assembly. At low temperatures, the forming of condensate may cause frost damages in the collector.

Lightning protection

Please note country-specific legislation!

Throughout the installation of metal fastening systems, a check has to be done by an authorized qualified electrician.

The metallic pipes of the solar circle are connected with the earth circuit connector via a copper pipe of at least 16 mm².

Please ensure sufficient ventilation for each assembly method. Do not close the ventilation openings. Especially in case of a roof-integrated assembly, the ventilation of the collector is definitely necessary. Appropriate ventilation hoods are available from the supplier. Please pay attention to the regulations of the ZVDH (Germany), SVDW (Switzerland) as well as different local regulations concerning the ventilation. If necessary, consult an expert.

Responsibilities

The constructor of the installation is responsible for the integration of the installation according to the regulations and for the compliance with safety regulations.

The operator of the installation is responsible for its operation according to the regulations and for the consultation of experts in case of problems.

This instruction is not subject to a service of modification. It does not absolve the manufacturer and operator of the installation from his responsibilities to install and operate all parts of the installation according to utmost professional knowledge. The manufacturer of the installation is responsible for observing and keeping all appropriate regulations and instructions.

Statics

Before beginning the assembly it is vital to test the roof or substructure on site for sufficient load-carrying capacity.

Please pay increased attention to the possible durability of the screw fittings to fasten the collectors as well as to the quality of the substructure.

According to DIN EN 1991 or rather to the local engineer standards, it is necessary to check the whole system construction on site, especially in snowy regions (note: 1m³ powder snow ~ 60 kg / 1 m³ wet snow ~ 200 kg) as well as in regions with high wind speed. Before starting the assembly, all aspects that may lead to incorrect load of the whole construction have to be considered!

Install the collectors in such a way that a backlog of snow (e. g. due to snow guards or other obstacles) is not possible.

In case of correct assembly, snow loads (pressure loads) up to 2 kN/m² and wind loads (suction loads) up to 1,1 kN/m² acting on the collector are permitted.

Transport and stocking

Never store the delivered collectors unprotected at the building site.

Always stock the collectors upright and leaning against a solid surface.

If the collectors are stored outside they must be stood upright with the backside leaned against the wall (glass forwards). The collectors must be covered so that neither dust nor water can enter the collectors.

If it is not possible to stand the collectors upright (e.g. flat roof), the collectors must be stacked with 2 square timbers between each collector.

Never lay down the collectors onto a rough surface with overhanging pieces like stones, timbers etc.

The rigidity of the collectors is limited. During transport to the building site always ensure a torsion-free transport. In case of an elevated intermediate storage make sure that the collectors are protected against sliding down.



Tools

The following tools are needed for the assembly of the collectors:



Cordless screwdriver



Angle grinder
diamond/stone disk



Chalk box



Allen screw SW 4 *, SW 6



Drill
10 mm carbid metal



Hammer



Knife



Ratchet, lengthening and 13 mm
socket wrench, combination wrench
13 mm



Securing devices,
protective equipment



Roof ladder

* included in the STI tool kit 2014

1910101



Product description



Solar collector FKF

The solar thermal collector FKF uses the radiant energy of the sun to heat a heat transfer medium. This glycol-water mixture gives off the heat to a storage via a heat exchanger. The obtained energy can be used for water heating and heating support.

Sectional model

- 1 Aluminium frame
- 2 Insulation
- 3 Insulation
- 4 Stucco back panel
- 5 Highly selective mono-material copper absorber
- 6 Glass
- 7 EPDM sealing

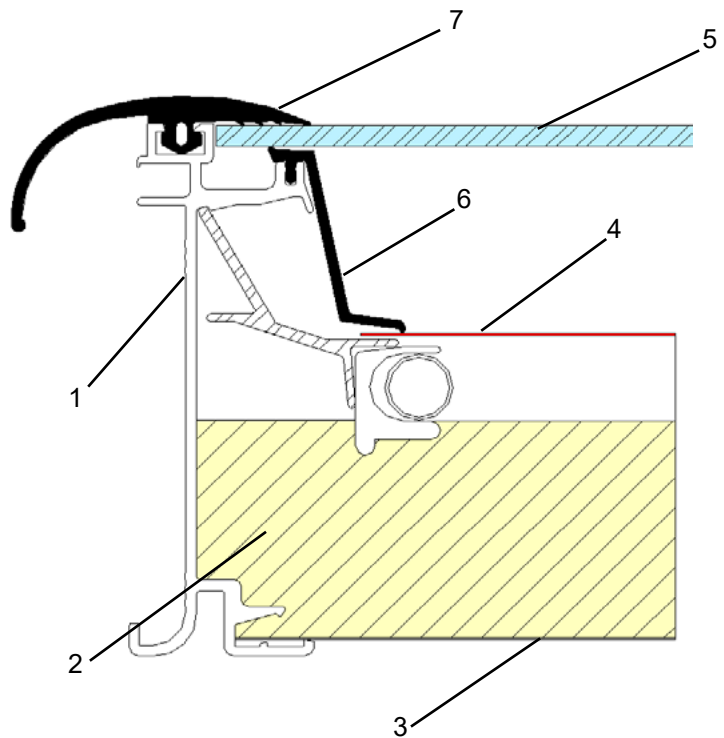

Product description

Specifications

The FKF collector has an absorber with meander shaped tubes as well as integrated manifolds. The hydraulic system enables a connection of 15 collectors in one series and up to six collectors on one side. In one collector field, up to 45 collectors can be connected in three rows.

Modell FKF	200 V	240 V	270 V	200 H	240 H	270 H
Gross surface	2,10 m ²	2,52 m ²	2,85 m ²	2,10 m ²	2,52 m ²	2,85 m ²
Apertur area	1,83 m ²	2,22 m ²	2,52 m ²	1,83 m ²	2,22 m ²	2,52 m ²
Length	1.746 mm	2.100 mm	2.373 mm	1.200 mm	1.200 mm	1.200 mm
Width	1.200 mm	1.200 mm	1.200 mm	1.746 mm	2.100 mm	2.373 mm
Height	85 mm	85 mm	85 mm	85 mm	85 mm	85 mm
Test pressure	10 bar	10 bar	10 bar	10 bar	10 bar	10 bar
Operating pressure	6 bar	6 bar	6 bar	6 bar	6 bar	6 bar
Fluid volume Co-Co / Al-Co	2,1 l	2,2 l	2,4 l	2,7 l	2,7 l	3,1 l
Fluid volume Al-Al	1,8 l	1,9 l	2,1 l	2,4 l	2,4 l	2,7 l
Flow per m ²	15 - 40 l/h	15 - 40 l/h	15 - 40 l/h	15 - 40 l/h	15 - 40 l/h	15 - 40 l/h
Weight Co-Co	37 kg	39 kg	42 kg	37 kg	39 kg	42 kg
Weight Al-Co	35 kg	37 kg	40 kg	35 kg	37 kg	40 kg
Weight Al-Al	34 kg	35 kg	38 kg	34 kg	35 kg	38 kg
Loss of pressure(T=20°C / 30l/h)	6.141 Pa	8.522 Pa	11.217 Pa	4.082 Pa	6.297 Pa	7.988 Pa

Hydraulic system of the absorber

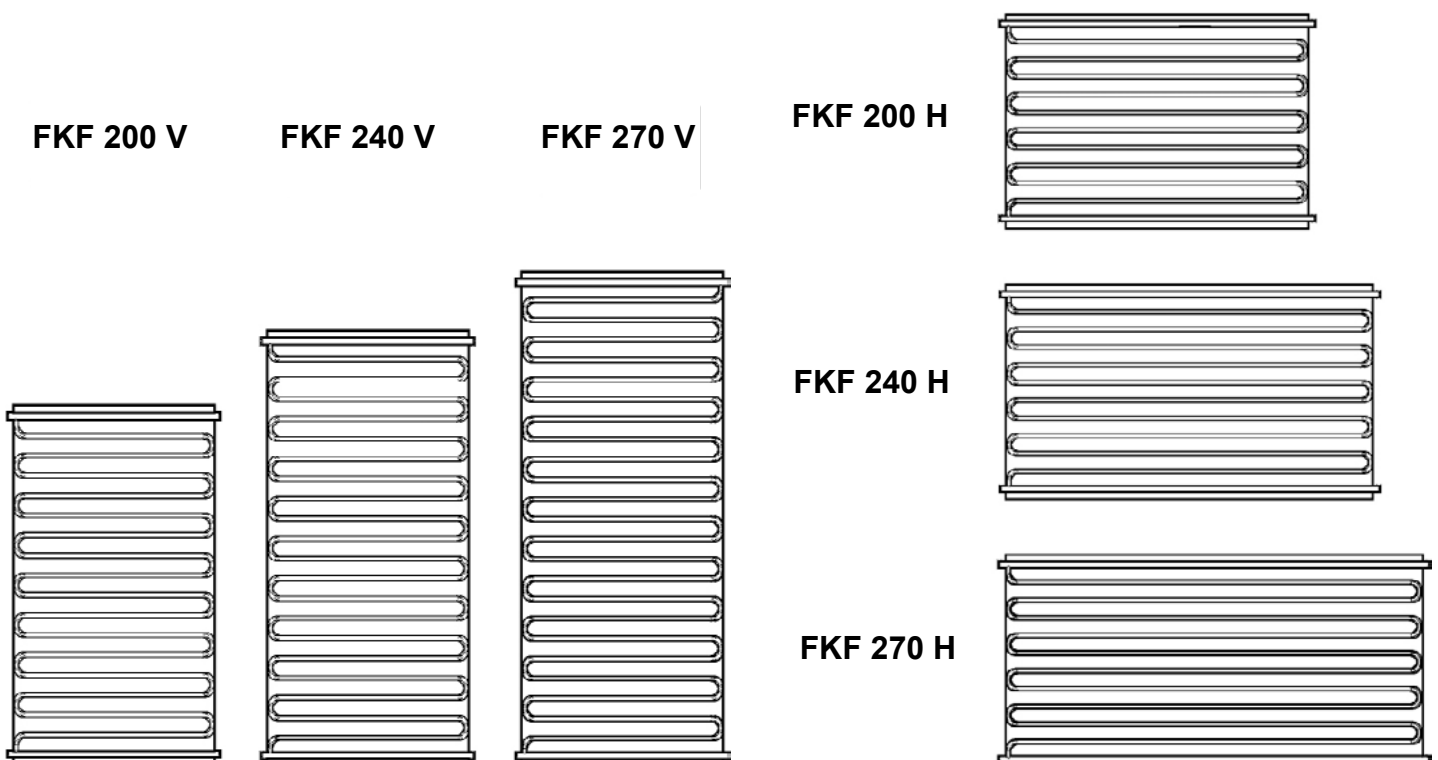

Collector field dimensions

Vertical section across a collector field

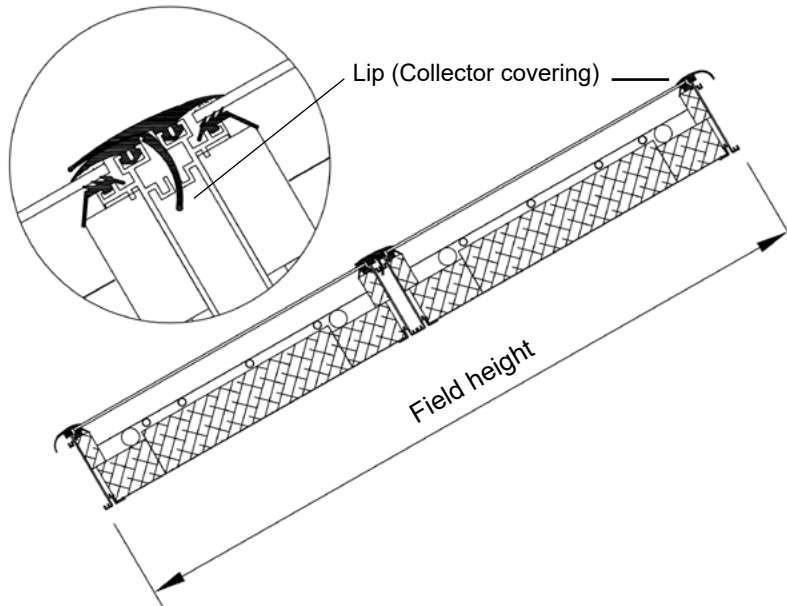

In case of multi-row installations, the collectors will always be mounted on joint on top of each other. The lip (collector covering) of the upper collector has to be put onto the lower collector. The lip (collector covering) of the lower collector has to be clamped into the joint area to ensure an optimum water flow.

Horizontal section across a collector field

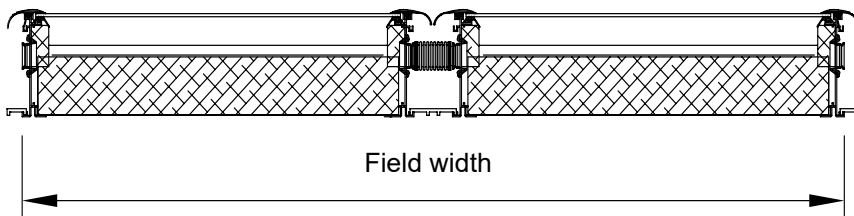

Collectors which are mounted side by side in one row are always connected by means of stainless steel expansion joints on the manifolds (see photo).

It is possible to assemble metal sheets between the collectors to achieve a homogeneous appearance of the installation. The intermediate plates are assembled exclusively for optical aspects and do not have any influence on the installation. Therefore the intermediate plates can be ordered optionally and are not necessarily included in delivery.



1300002 collector connection set hydraulic



Collector field dimensions

Collector type

200 V	Number of collectors	1	2	3	4	5	6	7	8	
	Field width in mm	1.167	2.387	3.607	4.827	6.047	7.267	8.487	9.707	+ 1.220
	Number of rows	1	2	3	4	5	6	7	8	
	Field height in mm	1.713	3.426	5.139	6.852	8.565	10.278	11.991	13.704	+ 1.713

200 H	Number of collectors	1	2	3	4	5	6	7	8	each additional collector
	Field width in mm	1.713	3.479	5.245	7.011	8.777	10.543	12.309	14.075	+ 1.766
	Number of rows	1	2	3	4	5	6	7	8	
	Field height in mm	1.167	2.334	3.501	4.668	5.835	7.002	8.169	9.336	+ 1.167

240 V	Number of collectors	1	2	3	4	5	6	7	8	each additional collector
	Field width in mm	1.167	2.387	3.607	4.827	6.047	7.267	8.487	9.707	+ 1.220
	Number of rows	1	2	3	4	5	6	7	8	
	Field height in mm	2.067	4.134	6.201	8.268	10.335	12.402	14.469	16.536	+ 2.067

240 H	Number of collectors	1	2	3	4	5	6	7	8	each additional collector
	Field width in mm	2.067	4.187	6.307	8.427	10.547	12.667	14.787	16.907	+ 2.120
	Number of rows	1	2	3	4	5	6	7	8	
	Field height in mm	1.167	2.334	3.501	4.668	5.835	7.002	8.169	9.336	+ 1.167

270 V	Number of collectors	1	2	3	4	5	6	7	8	each additional collector
	Field width in mm	1.167	2.387	3.607	4.827	6.047	7.267	8.487	9.707	+ 1.220
	Number of rows	1	2	3	4	5	6	7	8	
	Field height in mm	2.340	4.680	7.020	9.360	11.700	14.040	16.380	18.720	+ 2.340

270 H	Number of collectors	1	2	3	4	5	6	7	8	each additional collector
	Field width in mm	2.340	4.733	7.126	9.519	11.912	14.305	16.698	19.091	+ 2.393
	Number of rows	1	2	3	4	5	6	7	8	
	Field height in mm	1.167	2.334	3.501	4.668	5.835	7.002	8.169	9.336	+ 1.167

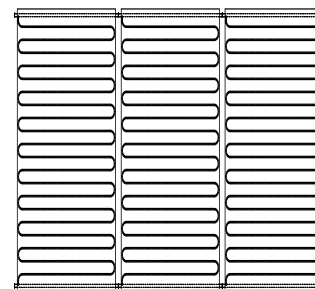

Example

Six collectors FKF 240 H in two rows

Field width: **6.307 mm**
Field height: **2.334 mm**

Example

Three collectors FKF 240 V in one row

Field width: **3.607 mm**
Field height: **2.067 mm**

Hydraulic connections

Temperature sensor

Each collector has a sleeve for inserting a temperature sensor. The sleeve is directly connected with the absorber. If the collectors are installed correctly, the sleeve is always located on the top of the collector on the left. The temperature sensor can be inserted in any collector. Please pay attention to the maximum insertion depth of 4 cm and secure the sensor against slipping out. Due to the measuring point on the absorber, the temperature measured by the sensor may differ from the fluid temperature.

Installations with one up to six collectors in one row

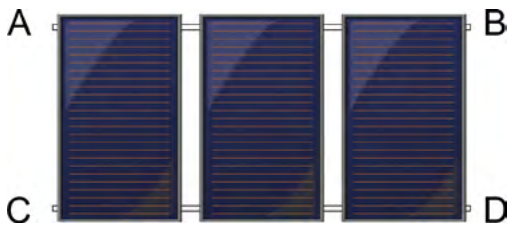

Connection F red A or B
Connection BF blue C or D

Close unused connections with caps.



Installations with seven up to 15 collectors in one row

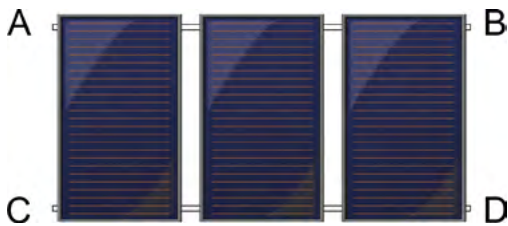

Connection bottom left / top right
 $BF = C / F = B$
Connection top left / bottom right
 $BF = D / F = A$
Close unused connections with caps.

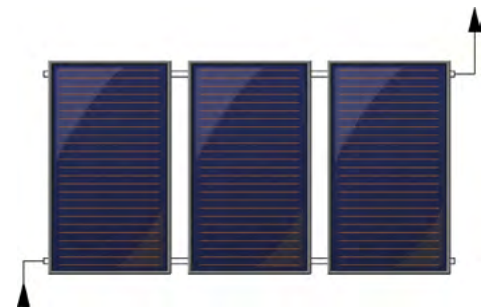

Multi-row installations

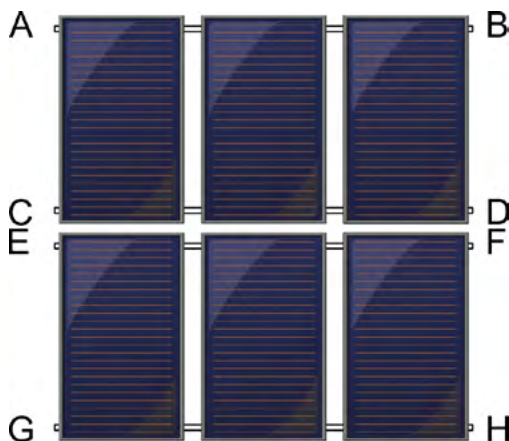

Connection F A + E / BF H + D
Connection F B + F / BF G + C

Close unused connections with caps.

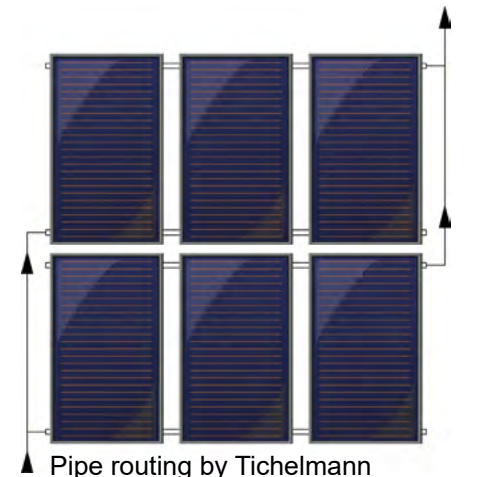

In case of multi-row installations as well as installations which include the STI Drain Back System, the connection pipe must always be connected with the diagonal line to the external manifold (Tichelmann), e. g. bottom left and top right.

F = Flow (from the collector to the storage) red grommet
BF = Backflow (from the collector to the storage) blue grommet
In case of installing an air eliminator, install it at the opposite end of the top flow connection!



Bottom support dimensions

Bottom support

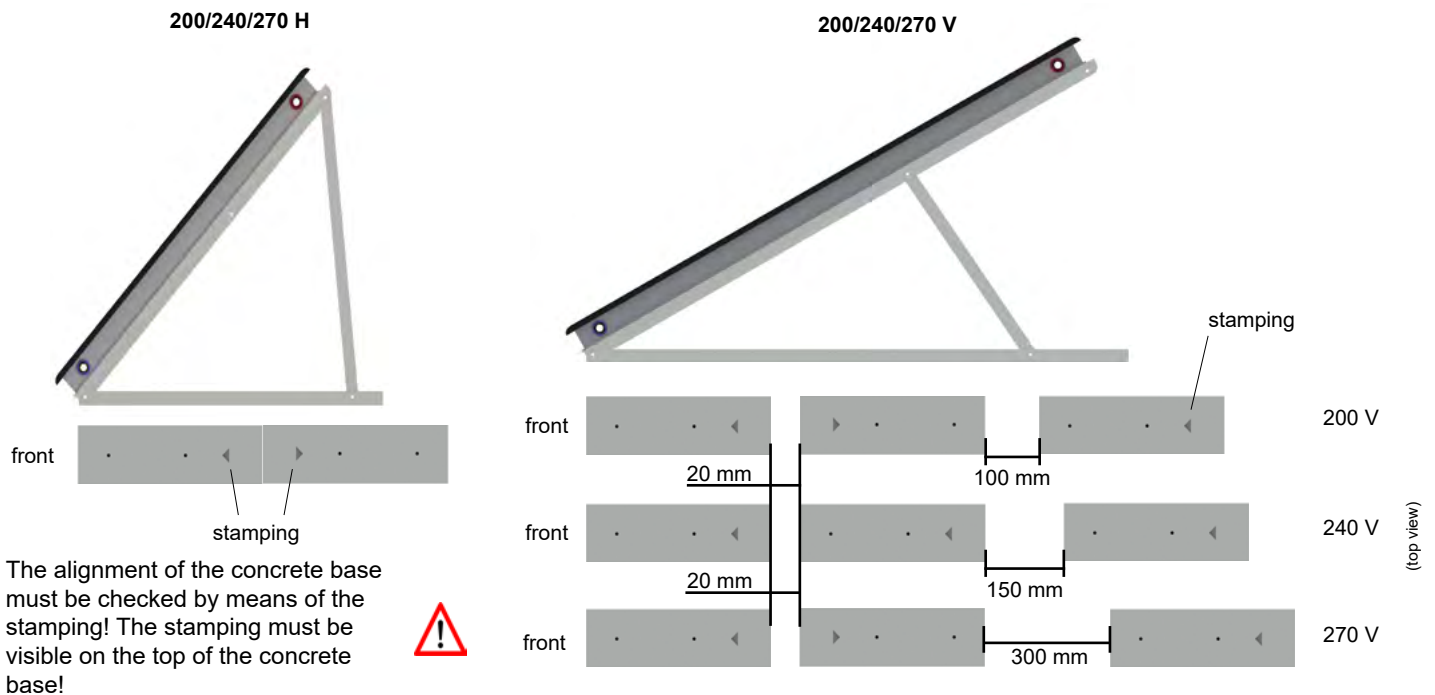

row spacing of collectors				
collector type	distance A			
	20 °	30 °	45 °	60 °
FKF 200 H	220 cm	265 cm	315 cm	340 cm
FKF 240 H	220 cm	265 cm	315 cm	340 cm
FKF 270 H	220 cm	265 cm	315 cm	340 cm
FKF 200 V	328 cm	391 cm	462 cm	503 cm
FKF 240 V	439 cm	513 cm	598 cm	646 cm
FKF 270 V	460 cm	550 cm	640 cm	700 cm

building height of collectors				
collector type	height H			
	20 °	30 °	45 °	60 °
FKF 200 H	53 cm	71 cm	93 cm	110 cm
FKF 240 H	53 cm	71 cm	93 cm	110 cm
FKF 270 H	53 cm	71 cm	93 cm	110 cm
FKF 200 V	73 cm	91 cm	132 cm	156 cm
FKF 240 V	84 cm	116 cm	158 cm	180 cm
FKF 270 V	95 cm	130 cm	176 cm	211 cm

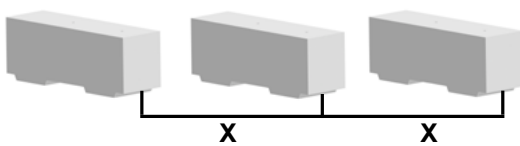

The specified levels are reported without concrete blocks. To determine the total height the height of the concrete block (22 cm) must be added.

Block distance center - center		Dimensional chain, bottom bracket UK mounting			
collector type	distance	Bottom support	Bottom support attachment points (+ / - 30 cm)		
	X		α	δ	ε
FKF 200 H	176,6 cm	1000 mm	100 mm	850 mm	-
FKF 240 H	212,0 cm	1000 mm	100 mm	850 mm	-
FKF 270 H	239,3 cm	1000 mm	100 mm	850 mm	-
FKF 200 V	122,0 cm	1600 mm	100 mm	870 mm	1.420 mm
FKF 240 V	122,0 cm	1600 mm	100 mm	720 mm	1.470 mm
FKF 270 V	122,0 cm	1800 mm	100 mm	870 mm	1.620 mm

Please note the wind loads according to DIN 1055-1991 in the edge region of the roof. The emerging base load has to be checked for the requirements of the wind loads on site.



Bottom support dimensions

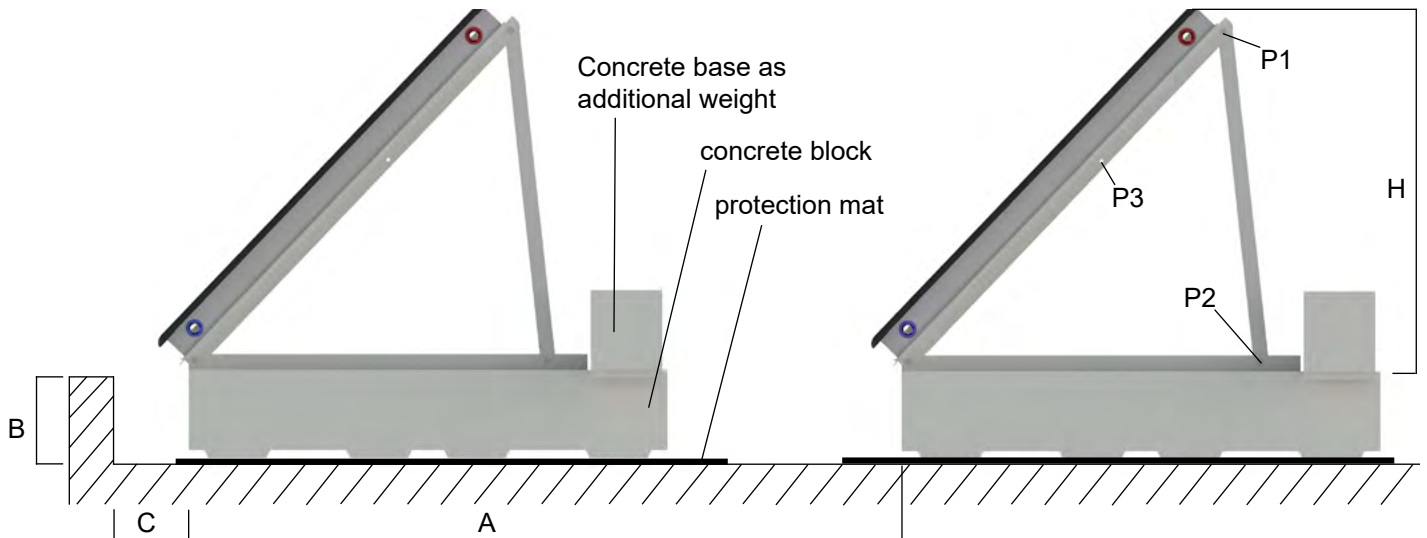

All indicated values are a recommendation for an effective sun angle of 20°.

travers position				
angle	20°	30°	45°	60°
position	P1 - P2	P3 - P2	P1 - P2	P3 - P2
FKF 200/240/270 H	487 mm	487 mm	861 mm	861 mm
FKF 200 V	675 mm	675 mm	1.224 mm	1.224 mm
FKF 240 V	832 mm	832 mm	1.490 mm	1.490 mm
position	P3 - P2	P3 - P2	P3 - P2	P3 - P2
FKF 270 V	659 mm	962 mm	1.405 mm	1.820 mm

distance of superstructures									
parapet height B	30 cm	40 cm	50 cm	60 cm	70 cm	80 cm	90 cm	100 cm	110 cm
distance C	20 cm	40 cm	70 cm	100 cm	125 cm	150 cm	180 cm	205 cm	230 cm

1420106 concrete block 53 kg



concrete block 53 kg
console 8 kg

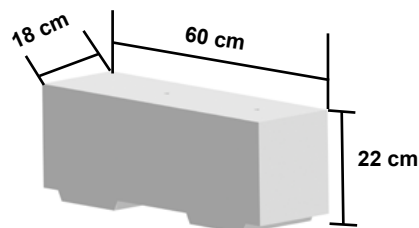

Declaration of the collector weight can be found on page 7.

Assembly bottom support on concrete block



First of all install the base console in accordance to the requirements of the dimensions of bottom support.

1420114 bottom support 20°/30° 200 V 2014
 1420124 bottom support 45°/60° 200 V 2014
 1420118 bottom support 20°/30° 240 V 2014
 1420122 bottom support 45°/60° 240 V 2014
 1420160 bottom support 20° 270 V 2014
 1420161 bottom support 30° 270 V 2014
 1420162 bottom support 45° 270 V 2014
 1420163 bottom support 60° 270 V 2014
 1420111 bottom support 20°/30° 200/240/270 H 2014
 1420120 bottom support 45°/60° 200/240/270 H 2014

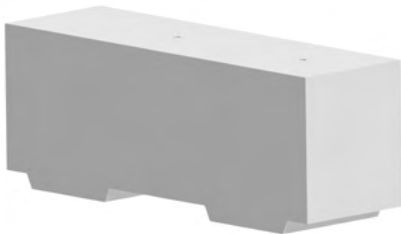

Afterwards place the concrete block. Pay attention to the exact observance of the specified clearances between the concrete blocks. If necessary, the usage of a separation layer between concrete block and subsurface has to be considered.

The short distance between threaded sleeve and block edge (10 cm) shows the front of the block. Make sure that every concrete block is on the same mounting position and aligned in a row (e.g. by a line mark).

1420106 concrete block 53 kg

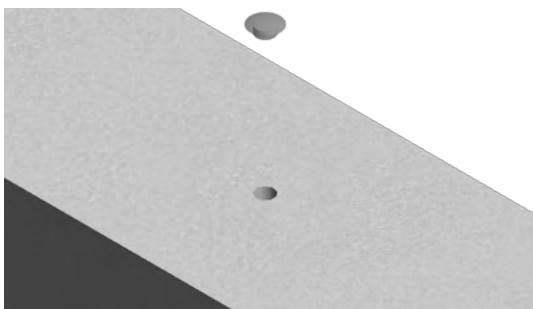

Now remove the protective caps for the integrated threaded sleeves from all concrete blocks.



Afterwards place the base console on the concrete block and secure them with the enclosed screws M10. All further consoles have to be oriented exactly in row (e.g. by a line mark).

1420003 fastening set for bottom support

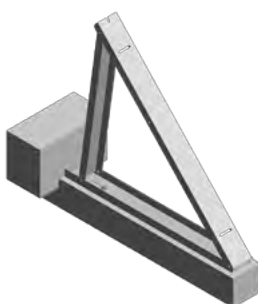

Now weight down the concrete block with an additional concrete block (optional). Prepare all consoles as described above for the assembly of the collectors. Alternative, a concrete element provided by the customer can be used for securing the base load.

1420106 concrete block 53 kg



Assembly bottom support with fixed dowel

Reliable anchoring of the bottom support with the fixed dowel pin is possible in concrete <c25/25 as well as in natural stone that is resistant to pressure.



First install the base console in accordance with the requirements (see page 13).



1420114 bottom support 20°/30° 200 V 2014
1420124 bottom support 45°/60° 200 V 2014
1420118 bottom support 20°/30° 240 V 2014
1420122 bottom support 45°/60° 240 V 2014
1420160 bottom support 20° 270 V 2014
1420161 bottom support 30° 270 V 2014
1420162 bottom support 45° 270 V 2014
1420163 bottom support 60° 270 V 2014
1420111 bottom support 20°/30° 200/240/270 H 2014
1420120 bottom support 45°/60° 200/240/270 H 2014



Drill two holes per base console in the existing surface to fix the fixed dowel pin M10. Pay attention to precise alignment of the two holes. In addition, all further holes have to be oriented exactly in one row (e.g. by a line mark).

1420004 fastening set for concrete blocks
(with fixed dowel pin M10)



Following place the base consoles on the ground and secure it with the added fixed dowel pins M10. All other consoles have to be oriented exactly in one row (e.g. by a line mark).

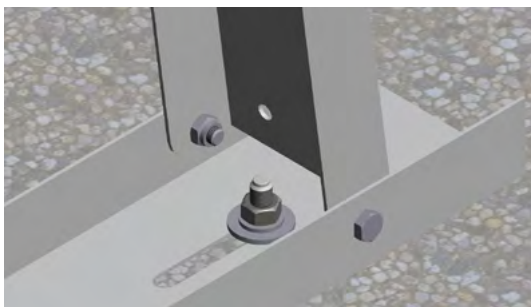
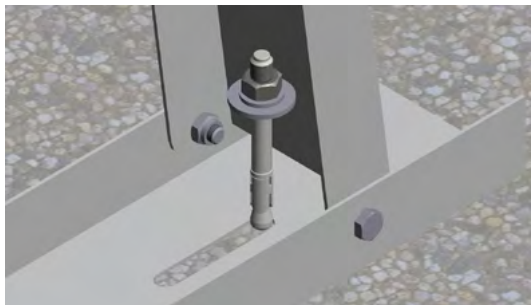

Fully assembled fixed dowel pin and console (see illustration alongside)



Assembly collectors

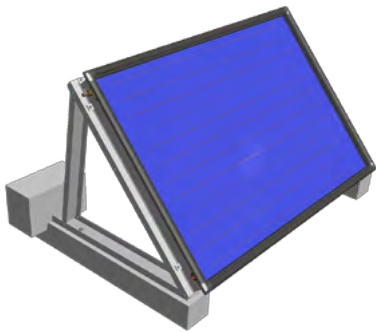

For the assembly of the collectors first place the outside right or outside left collector on top of the mounted and fixed base consoles. When assembling the collector, pay attention that the outside base console needs to be overlapped about 50% by the collector.

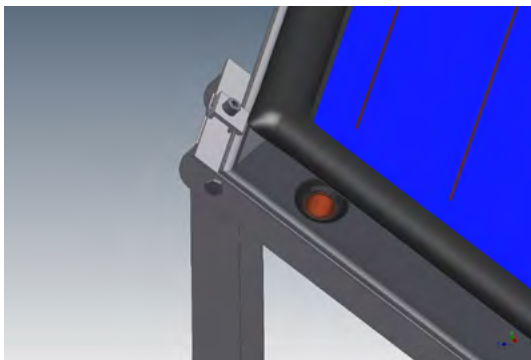

When the consoles are flush mounted with the outer collectors they will be secured with the provided fastening plates from the „collector fastening set onto support edge“ in conclusion. For this install the fastening plates at the upper and lower end of the console in the designated holes. When necessary, the consoles can be indented up to 20cm from the collector edge.

1400008 collector fastening set onto support edge
(4 pieces)



The mounting plate at the bottom of the consoles must be hung up with the broad side in the collector frame.



Afterwards mount the fastening plate „double“ on the next console in the upper and lower elongated hole. The final fixation takes place after the assembly of the next collector.

1400106 collector fastening set onto support 2014

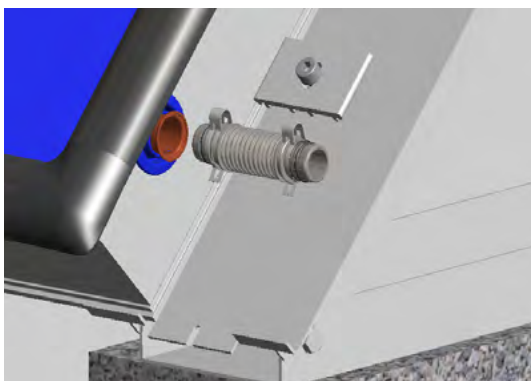

Before the following collector can be mounted, the hydraulic collector connection must be installed at the concisely protruding flange.

1300002 collector connection set hydraulic



Assembly collectors

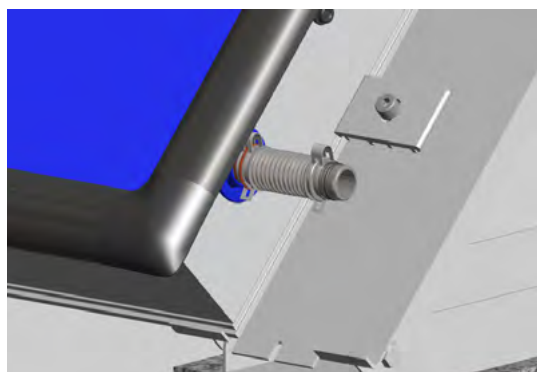

Insert the hydraulic collector connection into the manifold. Pay attention that both O-rings are mounted. Push the connection all the way to the stop and fasten it with the locking spring.

At the upper and lower collector connection, the hydraulic collector connection will be preassembled as to the image alongside.

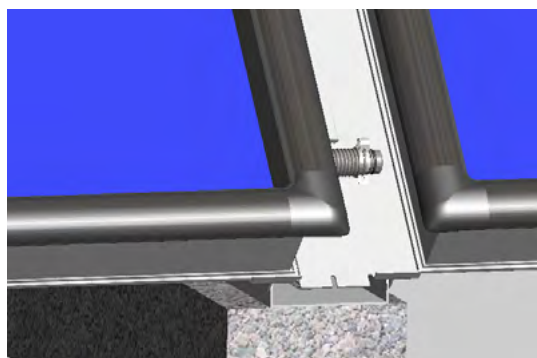

Push the next collector towards the already placed collector. Attention needs to be paid that the compensators are inserted into the collector manifold properly all the way to the stop.

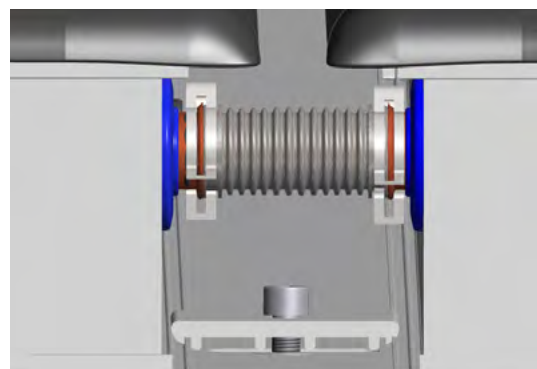

Pay attention that the fastening plate „double“ hooks into the collector profile on both sides. Afterwards, secure the fastening plate.



Finally, mount both outer fastening plates the way as assembled at the first collector.

Assembly collectors

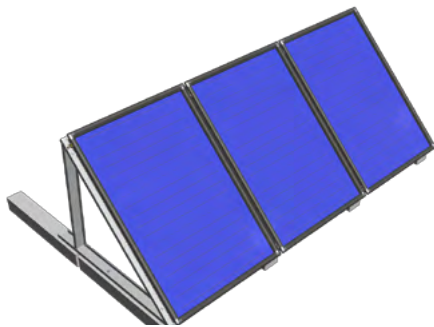

Now mount the next collector upon the consoles.

Assembly temperature sensor base console

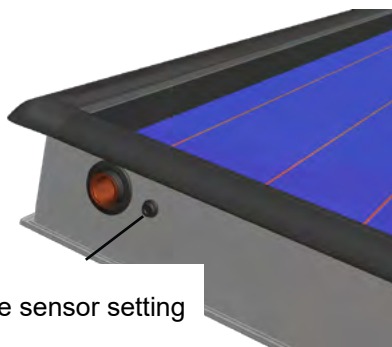

Temperature sensor setting

Each collector has a sleeve for inserting a temperature sensor. The sensor is positioned below the upper left manifold or next to the label with the description „top“ on the outside of the collector frame.

The sleeve for inserting the sensor is protected with a silicon lip which has to be opened in the middle, using a knife or a screwdriver, before inserting the sensor.

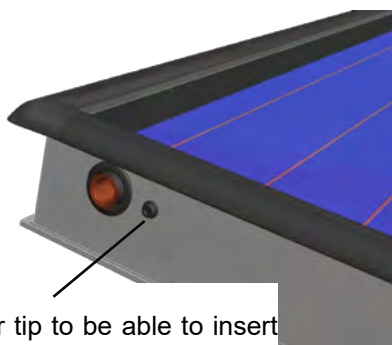

Cut rubber tip to be able to insert temperature sensor

The insertion depth of the sensor is limited to 4 cm. An additional protection against slipping out is recommended.

Contingent on the measuring point at the absorber the temperature sensor may be installed at any desired collector of the field.

The error of measurement of the recorded temperature compared to the fluid temperature is ± 2 K.

Assembly base console on roof profile

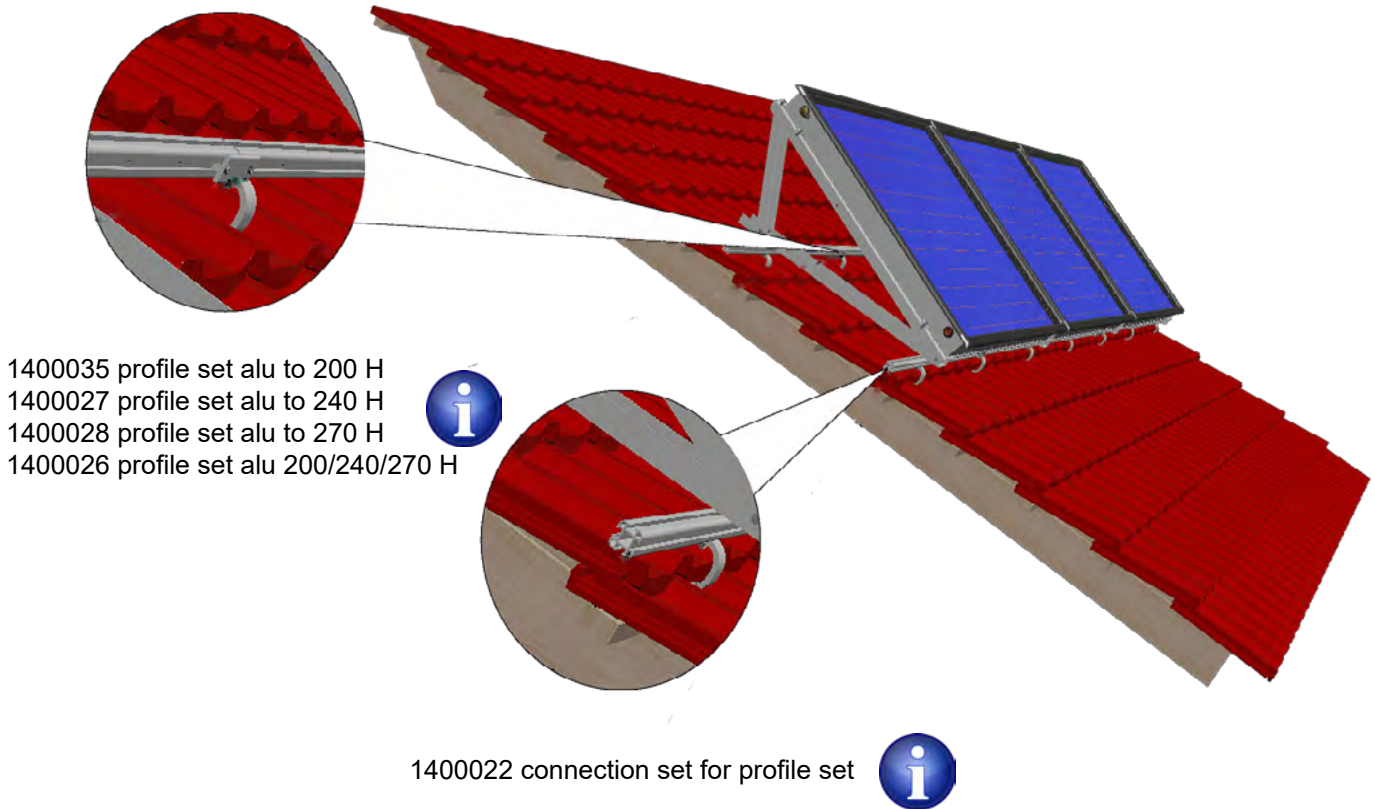

For roof-mounted installations profile sets dependent on the collector type are delivered. For multiple collectors in one row a connection set is required for each collector transition.

For multiple-row installations the minimum distances between the rows need to be adhered to (see table „row spacing of collectors“, bottom support dimensions).

Please pay attention that for the assembly of such a system a water-proof roof underneath needs to be built. For this it is necessary that the designated roof is provided with metal sheets, welding line, or plastic web from the eave to the crest.

Otherwise melted snow from the collector field may generate fields of ice. These may spread underneath the roof cladding and result in possible water damages in rooms below.



Spacing roof hooks

Distance measures roof-tiles

For each horizontal collector two rows of roof-tiles are installed and for vertical collectors three rows of roof-tiles are necessary. The vertical measurements H are each measured from the top edge of the roof-tile.

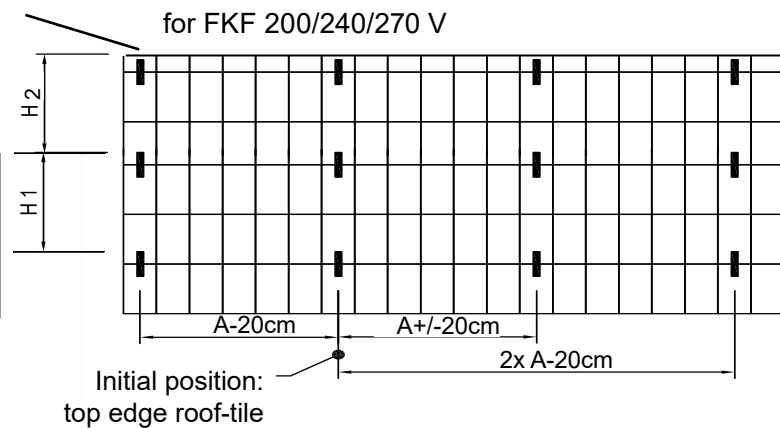
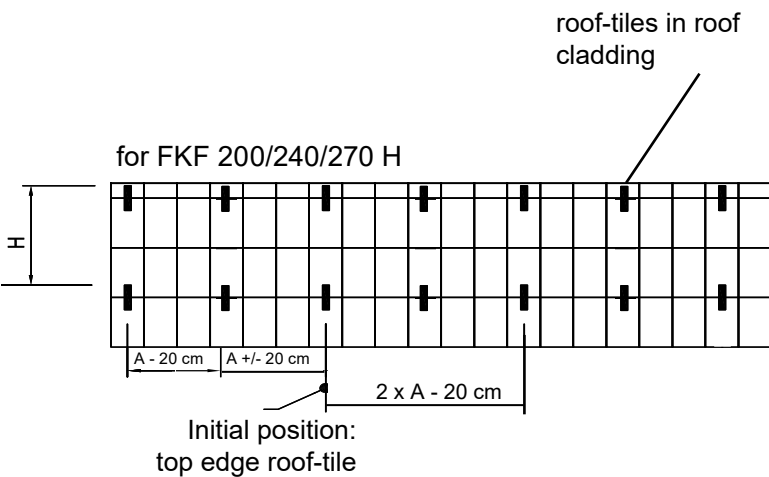

Horizontal size	FKF 200 H	FKF 240 H	FKF 270 H
Measure A	88,3 cm	106 cm	119,7 cm

Horizontal size	FKF 200 V	FKF 240 V	FKF 270 V
Measure A	122 cm	122 cm	122 cm

Vertical size	FKF 200 H	FKF 240 H	FKF 270 H
Tolerance	+ / - 4 cm	+ / - 4 cm	+ / - 4 cm
Measure H	76 cm	76 cm	76 cm

Vertikal size	FKF 200 V	FKF 240 V	FKF 270 V
Tolerance	+ / - 4 cm	+ / - 4 cm	+ / - 4 cm
Measure H 1	76 cm	76 cm	76 cm
Measure H 2	55 cm	55 cm	75 cm



- 1410002 roof-tile bracket V2 without lead
- 1410003 roof-tile bracket V2 with lead
- 1410004 roof-tile bracket (plain tile clamps) V2 without lead
- 1410005 roof-tile bracket (plain tile clamps) with lead



If high snow loads can be expected, the roof-tiles have to be mounted above the rafters (the supportive wood has to lie on the rafter). Alternatively, an increased amount of roof-tiles may be considered according to the load demand.

When the load capacity in the area of the lath is not given the assembly should happen on top of the rafter.

Assembly roof-tile clamps

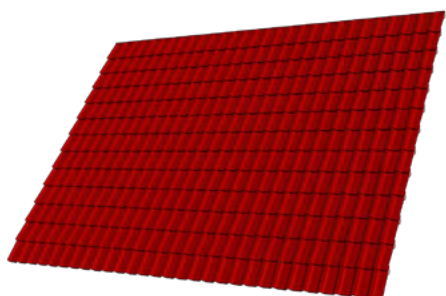

Completely tiled roof.

When mounting the field in regions with high snow load zone of 2 kN/m² it is necessary to place the roof hooks in the rafter area.



Removal of the tiles after previous determination of the placement of the roof-tile clamps (see page 11 „Spacing multi-row collector fields“).

Fixing of the lower lath 24 x 80 x 600 mm with two screws 5x60 mm.

If the lath is placed near the counter lath, the lath 24 x 80 x 600 mm must not be applied.

1410002 roof-tile brachet V2 without lead



The lath must be positioned in a way forcing the hook to be mounted in the brick vale.

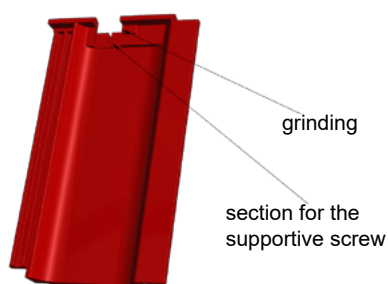

The lower roof-tile must be remounted.

Before covering, the lower roof-tile must be coarsly ground. To avoid breaking of the tile the roof-tile clamp must not rest on the tile.



Mount the tile clamp support 80x270x30 mm and fix it with two screws 5x60 mm.

Assembly roof-tile clamps



Besides the grinding of the roof-tile it is recommended to use a screw that is mounted on the roof-tile clamp support as distance saver.



Finished mounting of screw as distance saver.

If necessary, caulk the grinded brick with a foam tape against water!



Fix the roof-tile clamp with the support 50 x 150 x 5mm and two screws 5 x 60 mm.

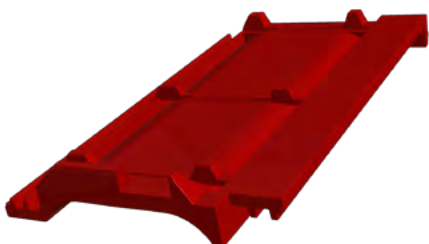

Before roofing the covering tile has to be coarsly ground accordingly.

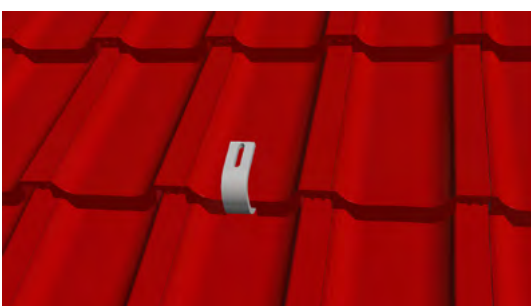

Completely covered roof-tile clamp after covering.

Further roof-tile clamps in one row must be adjusted exactly (e. g. by a line mark).

Assembly roof-tile clamps with lead cloth

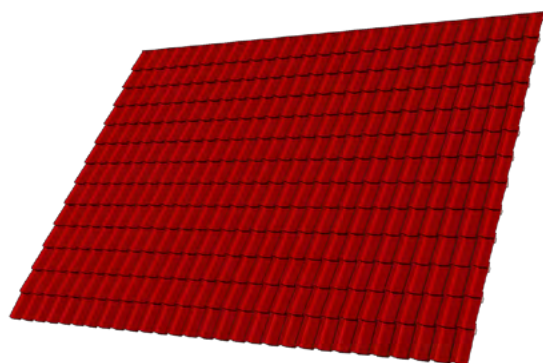

Completely tiled roof.

First, remove the adequate tiles after previous determination of the placement of the roof-tile clamps (see page 11 „Spacing multi-row collector fields“).

When mounting the field in regions with high snow load zone of 2 kN/m² it is necessary to place the roof hooks in the rafter area.



Completely uncovered area for placement of a hook.



Fix the lower lath 24 x 80 x 600 mm with two screws 4 x 50 mm.

If the lath is placed near the counter lath, the lath 24 x 80 x 600 mm must not be applied.

1410003 roof-tile bracket V2 with lead



Now remount the lower roof-tile.

Afterwards the tile clamp support 24 x 150 x 270 mm is to be fixed with two screws 6 x 60 mm.

Assembly roof-tile clamps with lead cloth



Place the first mounting cloth so that the lower tile is covered.

In addition, pay attention that the mounting cloth is put sideways underneath the adjoining tiles (bend up mounting cloth sidewise).



The roof-tile clamp must not cover the lower tile. Otherwise a pressure point on the lower tile may arise.



Mount the upper mounting cloth. Bend it up sideways. The screws of the roof-tile clamp have to be covered. Protect the mounting cloth against slipping, e.g. by seaming with upper lath.

The mounting cloth has to be positioned in a way that it is covered through the roof-tile.



The added foam wedge is placed under the adjacent tiles on both sides as well as above (protection against splash water and snow).



Completely mounted roof-tile clamp

Further roof-tile clamps in onew row must be adjusted exactly (e.g. by a line mark).



Assembly roof-tile clamps plain tile

Use the roof-tile for roof-mounted installation for plain tile roof covering also for slate, shingle and prefa covering.



Fixation of the lower lath 24 x 80 x 600 mm with two screws 4 x 50 mm.

If the lath is placed near the counter lath, the lath 24 x 80 x 600 mm must not be applied.

Adjust the roof-tile laterally so that only one tile must be coarsely ground. Place the hook so that there is enough space for a covering tile to avoid grinding.

The tile clamp is fixed with two screws 5 x 60 mm.

The roof-tile clamp may not rest or rather cause pressure points on the tile.

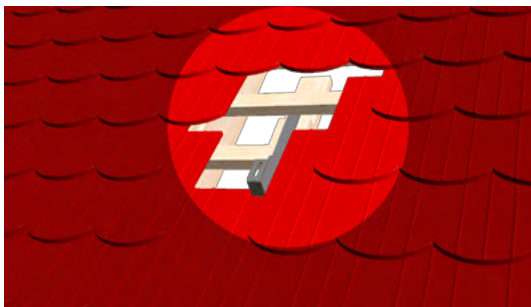

If the tile clamp is mounted too low, the added 5 mm timbers can be placed under the tile clamp.

When mounting the field in regions with high snow load zone of 2 kN/m², it is necessary to place the roof hooks in the rafter area.



Covering of tile laterally.



Grinding and covering of the tile.

Covering of the remaining tiles.

Further roof-tile clamps in one row must be adjusted exactly (e.g. by a line mark).

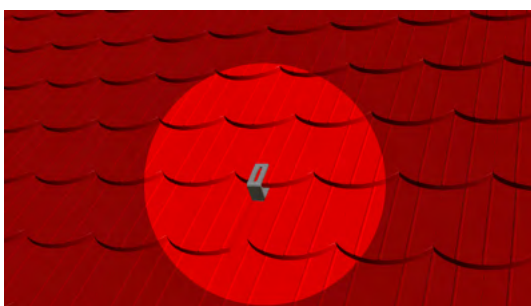

1410004 roof-tile bracket (plain tile clamps) V2 without lead



Assembly roof-tile clamps plain tile with lead cloth



Fixation of the lower lath 24 x 80 x 600 mm with two screws 4 x 50 mm.

Assembly of the upper tile clamp support 100 x 80 x 25 mm with two screws 5 x 60 mm.

When mounting the field in regions with high snow load zone of 2 kN/m², it is necessary to place the roof hooks in the rafter area.



Assembly of the lower tile clamp support 80 x 50 x 45 mm with two screws 5 x 60 mm.

Timber excess length of 5 mm (timber is higher than tile).

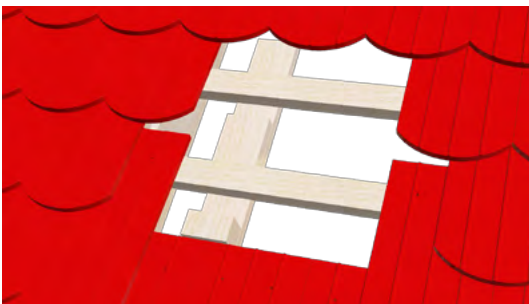

Completely mounted timber supports.



Mount the lower lead sheet while placing the lead laterally under the tiles.

Assembly roof-tile clamps plain tile with lead cloth



Pay attention that the corners are bent under the tile on both sides, to avoid a slipping off downwards.

1410005 roof-tile bracket (plain tile clamps)
with lead



Fixation of the roof-tile clamp with two screws 5 x 60 mm.

Screw the lower one into the tile lath and the upper one into the tileclamp support.



Completely mounted roof-tile clamp with lower lead sheet.

The tile clamp must have a minimum distance to the underlying tile of 5 mm.



Mount the upper lead sheet while placing the lead laterally under the tiles.

Pay attention that the corners are bent under the tile on both sides to avoid a slipping off downwards.

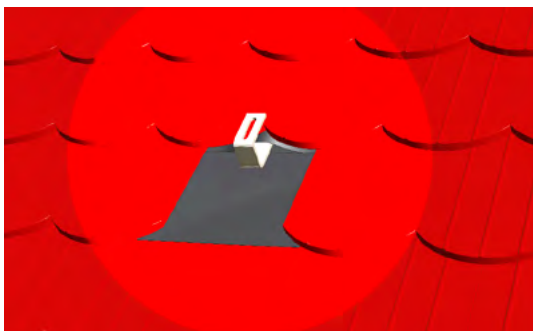

Covering of the upper tiles.

Completely mounted roof-tile clamp.

Further roof-tile clamps in one row must be adjusted exactly (e.g. by a line mark).



Assembly roof-tile clamps for corrugated sheet

The screws from the set for corrugated sheet covering are suitable for roof with a wooden subconstruction. For metal subconstructions the fasteners have to be provided by the customer.



Pay attention that the clamps are always mounted on top of an existing subconstruction.

1410001 roof-tile bracket V2 corrugated

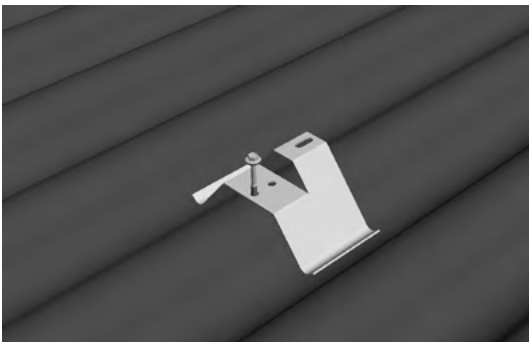

The holes for the fixation screws have to be pre-drilled with a 8 mm borer.

The fixation of the clamps is realised by façade screws 6.5 x 100 mm with sealing gasket.

Depending on the width of the substructure underneath the corrugated roof covering the roof clamp can additionally be fixed with a second fastening screw.



Completely mounted roof clamp ready for assembly of fastening profiles.

If the roof clamps can not be mounted within the limits indicated (see "Spacing roof hooks"), firstly horizontal or vertical STI system profiles have to be mounted onto the roof clamps. Afterwards the added fastening profiles are to be mounted.

Assembly fastening profiles / console

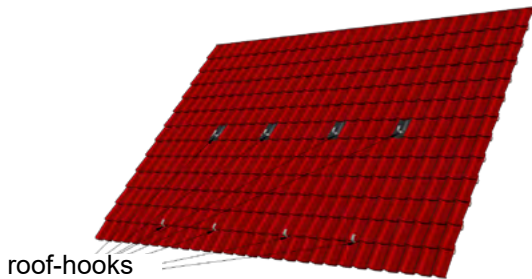

roof-hooks

Pre-assembled roof-tile clamps for a collector field with two collectors.

Top: tile removed and clamp set with lead cloth

Bottom: tile coarsly ground and clamp set without lead cloth

Assembly sequence profile sets

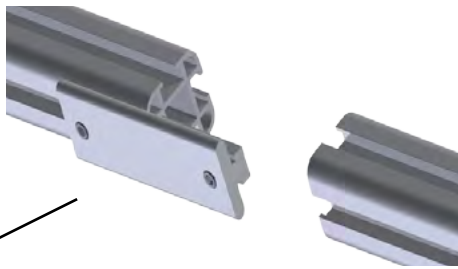

At the edge area of the fastening profiles that are to be mounted the connection profile will be inserted and centered.

The connection profile is to be mounted in each collector row.

1400022 connection set for profile set



profile set Vario Fix 200 V, 240 V, 270 V
 profile set Vario Fix 200 H
 profile set Vario Fix 240 H
 profile set Vario Fix 270 H

profile set aluminum for 200/240/270 V
 profile set aluminum for 200 H
 profile set aluminum for 240 H
 profile set aluminum for 270 H

profile set Vario Fix 200 V, 240 V, 270 V
 profile set Vario Fix 200 H
 profile set Vario Fix 240 H
 profile set Vario Fix 270 H



Assembly fastening profiles / console

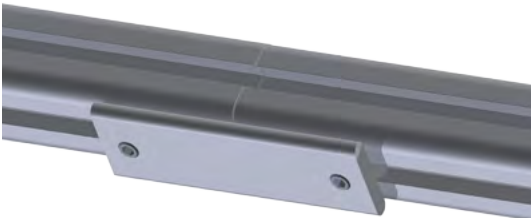

Connect the pre-assembled profile rails with the connection pieces. Fix all setscrews M8 x 12 mm within the connectors as well as the collector stop set.

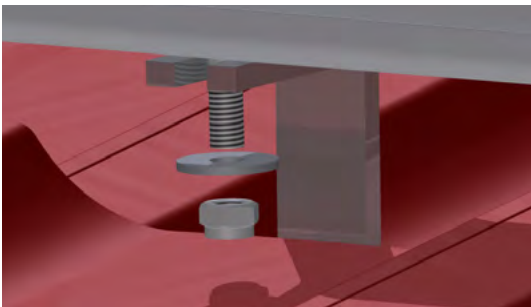

Mount the profile rails on top of the roof-hooks. For this, lead the square-head bolt through the elongated hole of the roof-hook and fix it with the washer and nut.

The maximum torque of max. 17 Nm for the connection - self-retaining nut M8 and square-head bolt M8 to the assembly of the fastening profile must not be exceeded.

The elongated hole within the roof hooks serve for the compensation of on site surface irregularities.



Ahead of the final fixation of the fastening profiles onto the roof hooks, the precise position needs to be proved in advance (water level, line mark).

Fasten the base console with the square-head bolt on top of the profile rails.

The maximum torque of max. 17 Nm for the connection - self-retaining nut M8 and square-head bolt M8 to the assembly of the fastening profile must not be exceeded.

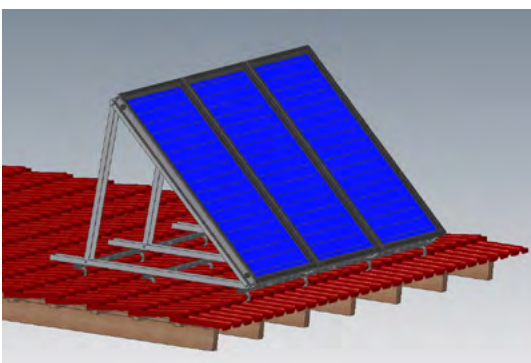

Assemble the collectors on the consoles according to the description starting at page 15.

Assembly wall console

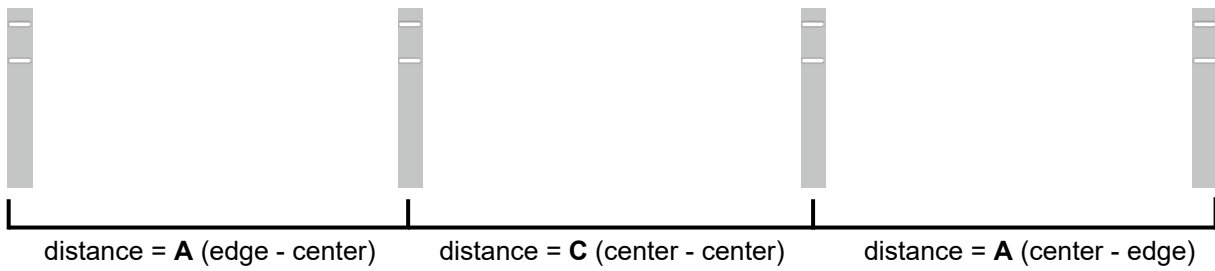

collector type	FKF 200 H	FKF 240 H	FKF 270 H
measure A	1.667 mm	2.020 mm	2.293 mm
measure C	1.769 mm	2.122 mm	2.395 mm

When mounting the collectors, the dimensions indicated above should be used.

According to choice, the outer consoles may be mounted up to 20 cm inserted at each edge of the collector field. In that case the fixation of the collectors happens at the upper collector profile, not at the lateral one.

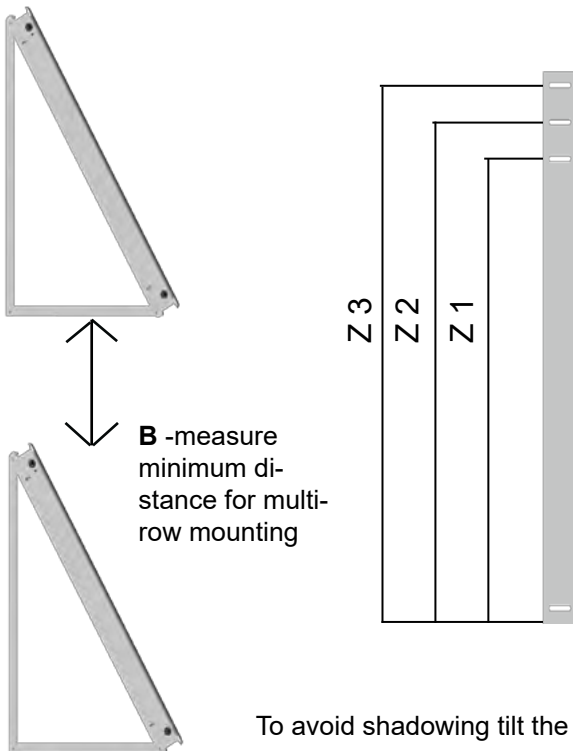
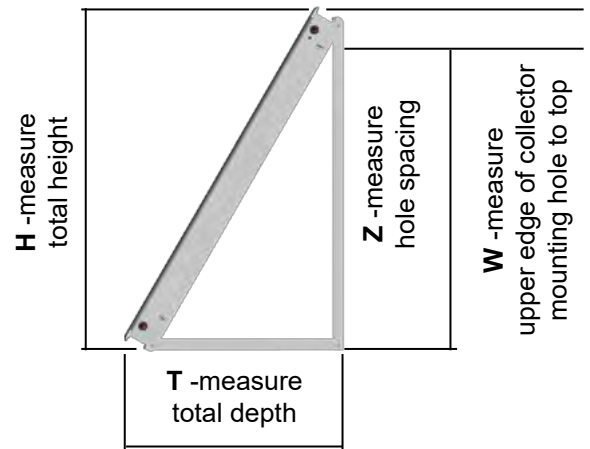

angle	20°	30°	45°
measure B	808 mm	1.106 mm	1.492 mm
measure H	1.140 mm	1.070 mm	910 mm
measure T	540 mm	710 mm	930 mm
measure W (top of collector to hole center)			
upper hole	96 mm	117 mm	140 mm
middle hole	176 mm	197 mm	220 mm
bottom hole	256 mm	277 mm	300 mm
measure Z (hole spacing of wall-side fixing holes)			
Z 1	834 mm	753 mm	578 mm
Z 2	914 mm	833 mm	658 mm
Z 3	994 mm	913 mm	738 mm

To avoid shadowing tilt the lower collector.



Assembly wall console

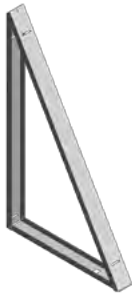

Wall console for assembly of collectors on façades, balcony railings or other vertical building sections.

Pre-assemble the wall console according to the guidelines of page 28.

1430101 wall console 200/240/270 H 20°
to wall 2014

1430102 wall console 200/240/270 H 30°
to wall 2014

1430103 wall console 200/240/270 H 45°
to wall 2014



Then place the wall console at the desired position. Make sure that all consoles have the same mounting position, the corresponding distance measures between the consoles, and the exact orientation in a range (e.g. by a line mark).



The fastening of the console on the wall takes place on site. It is necessary to inspect the assembly subsurface and choose an adequate fastener (see illustration alongside).

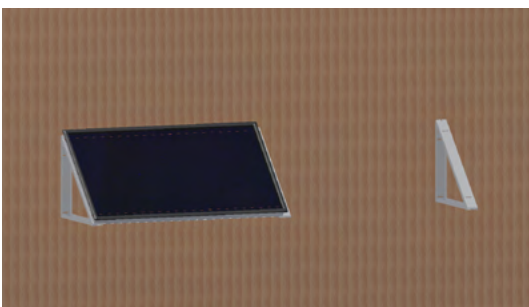

Following, place the first collector on the pre-assembled consoles.

Assembly wall console

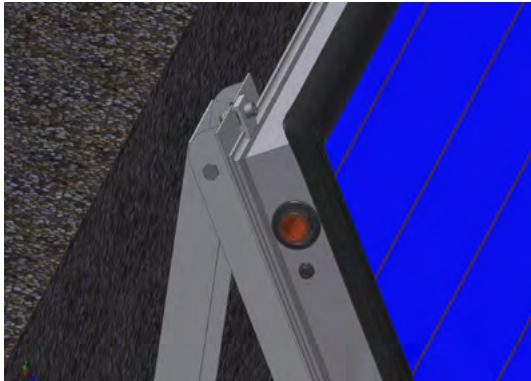

When the consoles are mounted succinctly with the outer collectors they are to be fixed conclusively with the provided fastening plates. To do so, mount the fastening plates at the upper and lower end of the console in the designated holes.

If required, the consoles may be inserted up to 20 cm from the edge of the collector.



1400008 collector fastening set onto support edge
(4 pieces)

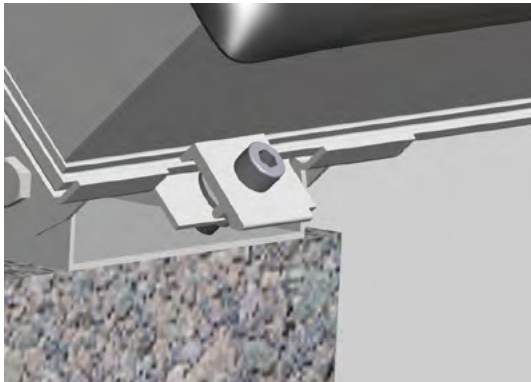

The mounting plate at the bottom of the consoles must be hung up with the broad side in the collector frame.

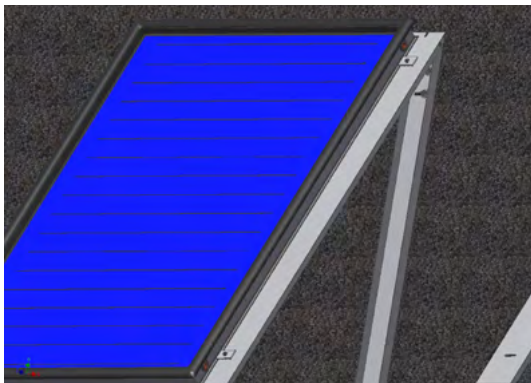

Following, pre-assemble the fastening plate „double“ in the upper and lower elongated hole on the next console. The final fixation happens after the next collector assembly.

1400106 collector fastening set onto support 2014

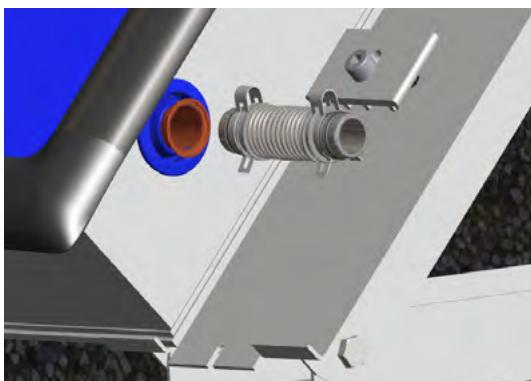

Before the installation of the next collector can happen the hydraulic collector connection must be mounted at the succinctly salient collector connection.

1300002 collector connection set hydraulic



Assembly wall console

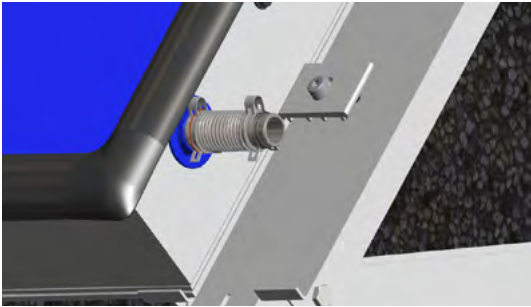

Insert the hydraulic collector connection into the manifold. Thereby pay attention that both O-rings are mounted. Slide-in the connector all the way into the manifold and secure it with the locking spring.

At the upper and the lower collector connection the hydraulic collector connector is to be assembled according to the image alongside.

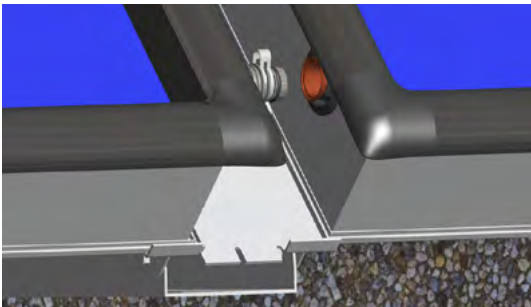

Now mount the next collector onto the consoles.

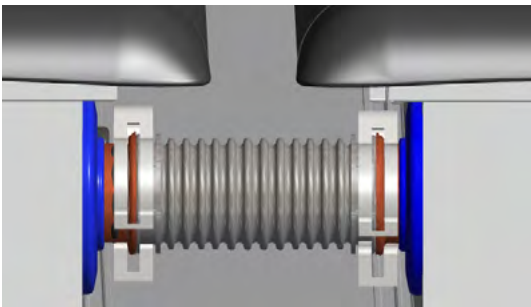

Push the next collector at the already present collector. For this it is to be considered that the compensator is inserted properly all the way into the collector manifold. Secure the hydraulic connector with the locking spring.

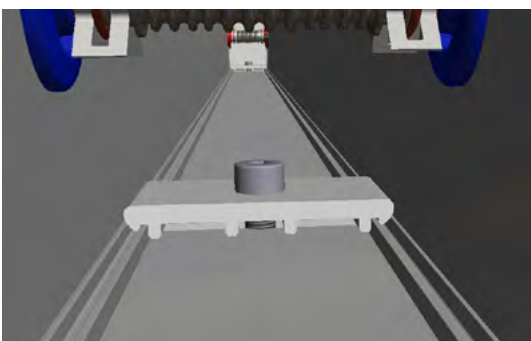

Pay attention that the fastening plate „double“ clasps on both sides into the collector profile. Afterwards secure the fastening plate.

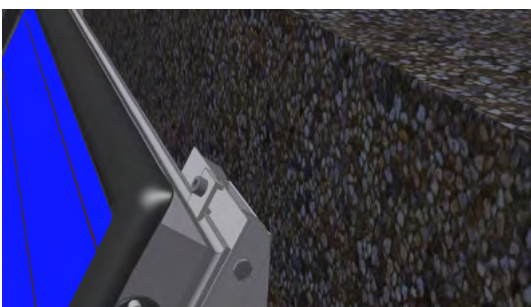

Finally, mount both outer fastening plates in the way like the first collector.

Assembly temperature sensor wall console

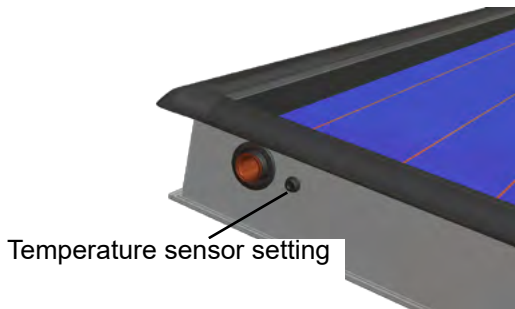

Each collector has a sleeve for inserting a temperature sensor. The sensor is positioned below the upper left manifold or next to the label with the description „top“ on the outside of the collector frame.

The sleeve for inserting the sensor is protected with a silicon lip which has to be opened in the middle, using a knife or a screwdriver, before inserting the sensor.

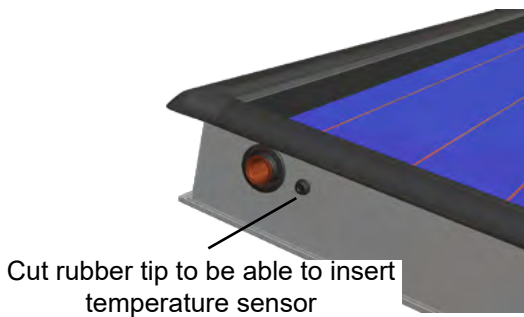

The insertion depth of the sensor is limited to 4 cm. An additional protection against slipping out is recommended. Contingent on the measuring point at the absorber the temperature sensor may be installed at any desired collector of the field.

The error of measurement of the recorded temperature compared to the fluid temperature is ± 2 K.

Collector connections



The cap will be mounted at all collector connections that are not used.

- 1310209 cap set SLS (2 pieces complete)
- 1310119 cap set aluminum SLS (2 pieces complete)



Connection 3/4"

- 1310205 collector connection set 3/4" SLS
(2 pieces complete without cap)



Connection for soldered fitting or clamping ring junction

- 1310204 collector connection set 22 mm SLS
(2 pieces complete without cap)
- 1310114 collector connection set 22 mm aluminum SLS
(2 pieces complete without cap)



Air eliminator without extension

- 1310207 air eliminator set without extension SLS
(complete with cap)



Completely mounted air eliminator

All other connections as well as the covers are mounted in the same way. Pay attention not to cover the temperature sensor setting.

The pictured air eliminator is only suitable for usage with copper pipes.



The required connection dimension must be calculated by the designer of the installation, depending on local conditions (line lengths, additional resistors etc.).

The connection or collecting pipe shall be secured with a clamp at the collector support for tug relaxation. This has to be provided by the customer.



Hydraulic connection with manifold

Hydraulic connections for multi-row installations

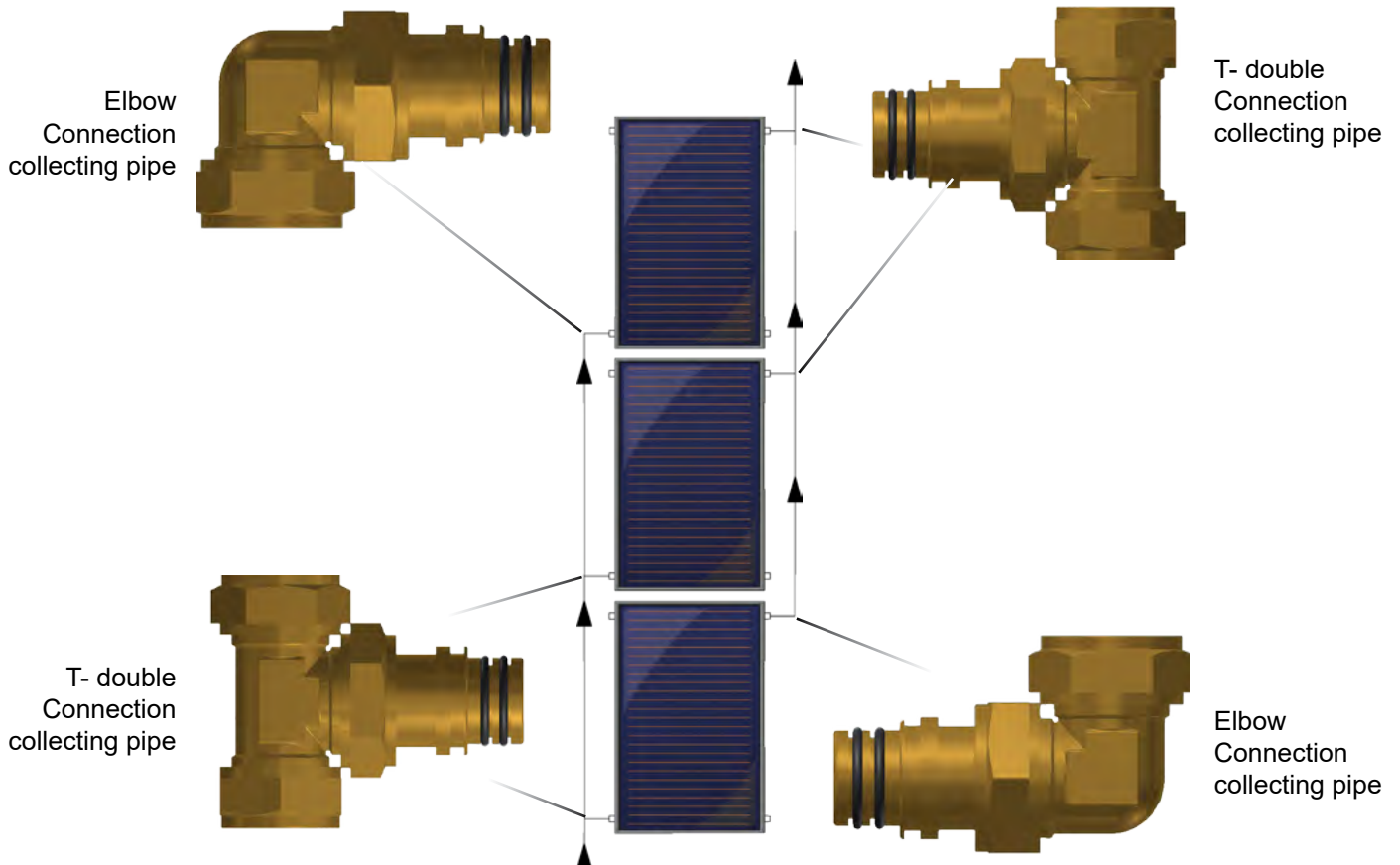
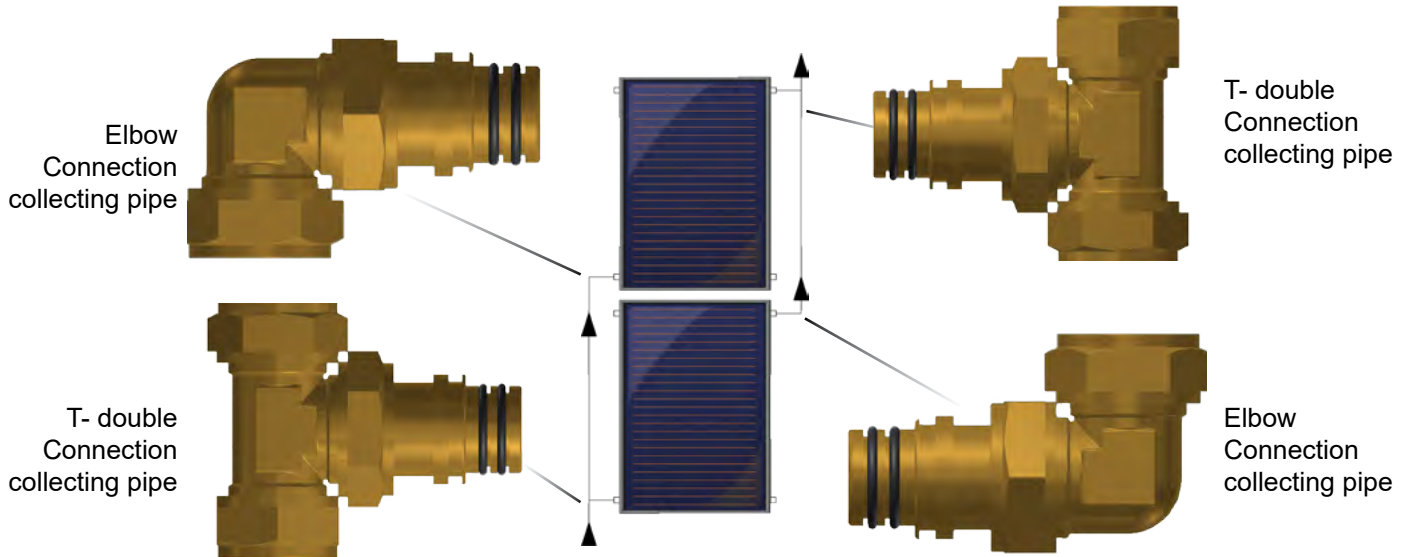

The lateral collecting pipes are available packaged at STI.

Overview hydraulic connections Smart Lock System / accessories

Hydraulic connections



Air elimination connection for assembly at collector without extension
Smart Lock System

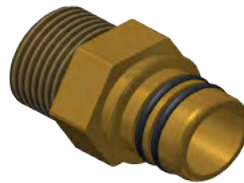

Collector connection 3/4" for thread fittings
Smart Lock System



Collector connection 22 mm for soldered fittings or clamping ring joints
Smart Lock System



Collector connection hydraulic (compensator) connects two collectors and compensates thermal dilations
Smart Lock System



Clamp collector connection and O-Ring - Clamp for connection of the above mentioned hydraulic devices with the flange at the collector

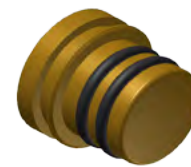

Cap
Smart Lock System

Accessories



Tool set



Spare set hydraulic



Spare set assembly

Overview hydraulic connections Smart Lock System / accessories aluminium

Collector connections aluminum for collectors with aluminum pipe



Collector connection 22 mm aluminum
Smart Lock System



Cap aluminum
Smart Lock System



Collector connection hydraulic
(compensator)



Hydraulic connection elbow 90°
Press-fit M-contour



Hydraulic connection T-piece
Press-fit M-contour



Safety line

Please note for full aluminum absorber:

Please pay attention to the following instructions for use concerning installation of collectors with mono-material aluminum absorbers (aluminum plate, aluminum pipe)

- All hydraulic fittings of the collector must be made of aluminum or stainless steel.
- Hydraulic system components made of brass and copper should only be installed with a minimum distance of 2.5 m from the collector field.
- Make absolutely sure that neither brass nor copper swarf is within the hydraulic system.
- The solar installation must be a closed system. Additional air entry from the outside must definitely be avoided. For this reason, open installations or installations that are directly flooded with drinking-water do not exist.
- The used glycol must contain appropriate inhibitors. Additionally, the guidelines of the glycol manufacturers must be kept to guarantee the long-term protection of the system.
- Recommended and proven heat transfer medium: Tyfocor ® L made by Tyforop GmbH.
- Make quite clear on the solar station, pump or control that collectors with mono-material aluminium absorber are installed.

Assembly intermediate plates

To achieve a homogenous appearance of the collector installation an assembly of plates inbetween the collectors is possible. The intermediate plates are mounted for optical aspects only and do not influence the system functionally. For that reason, intermediate plates may be ordered optional and are not mandatory included in the delivery contents.

Intermediate plates for the assembly in one row



For the collector types FKF 200 V, FKF 240 V and FKF 270 V in each collector transition two intermediate plates are to be mounted. For the collectors FKF 200 H, FKF 240 H and 270 H an assembly of one intermediate plate is designated. The intermediate plates may be mounted from the top or from the bottom.

Intermediate plat

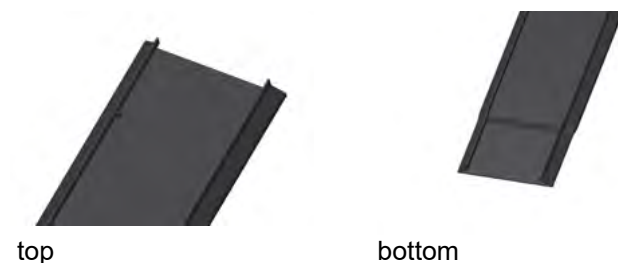

It is recommended not to mount the intermediate plates when there is an increased sun radiation or temperature. The possible thermal expansion of the collector may cause a difficult assembly.

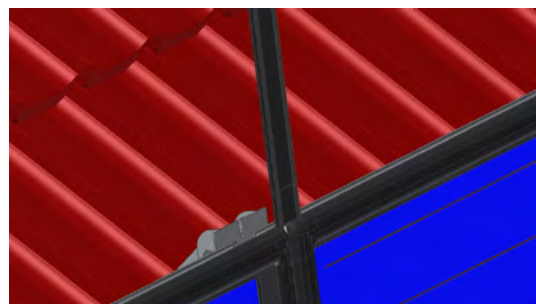

The intermediate plate will be inserted from the top/bottom into the collector groove. For vertical collectors further intermediate plates will be pushed behind from the top/bottom. The intermediate plate will be inserted until it arranges succinctly with the lip (rubber lip).

When assembling the intermediate plates pay attention to the water course from each upper to the lower intermediate plate.

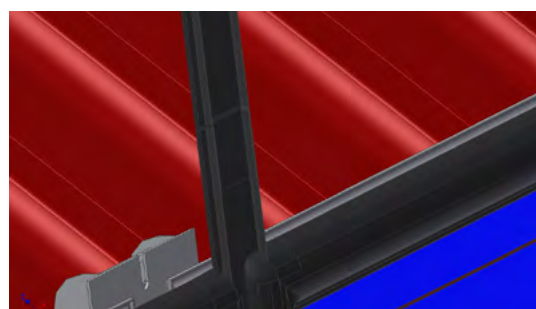

- 1200531 intermediate plate FKF 200 V
- 1200532 intermediate plate FKF 240 V
- 1200533 intermediate plate FKF 270 V
- 1200534 intermediate plate FKF 200 H/240 H/270 H



To avoid injuries it is recommended to push the intermediate plates with a piece of wood into the collector grooves.

Afterwards the intermediate plate will be caulked with the collector groove to secure it from slipping out. The silicone strip should have a length of 10 - 20 cm. Please pay attention that the intermediate plate must be free of leftover glue to assure the draining of rainwater.

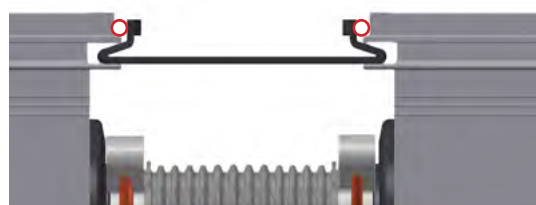

Assembly of the connecting pipe



The connecting pipe may be adjusted individually. For this, the stainless steel corrugated pipe is to be cut into the adequate length. Use a pipe cutter. Check the pipe endings for contamination, deformation and edge freedom.

Please pay attention that only the connecting pipe DN20 l=15 m can be adjusted individually. All other stainless steel corrugated pipes from the STI-portfolio are delivered in fixed length.

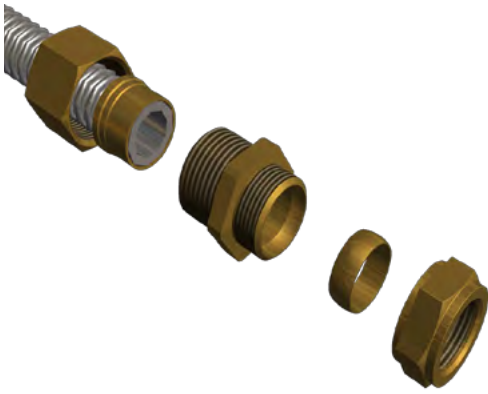

1320304 connection pipe DN20 l=15 m,
PES isolation



In the next step the components are pushed upon the pipe ending according to the image alongside. Pay attention that the pipe is pushed through the clinch ring all the way to the stop into the fitting. Tighten the cap nut hand-tight. Afterwards the nut will be tightened with 3 1/2 to 4 rotations with appropriate wrenches. In general, the whole connection is to be checked for leakproofness according to authorized valid regulations of the engineering after completion.

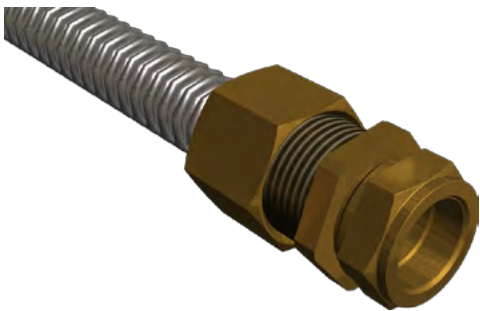

Completely mounted connecting pipe with screwing.

1320320 connection set for connection line
22 mm connector
1320321 connection set for connection line
22 mm screwing

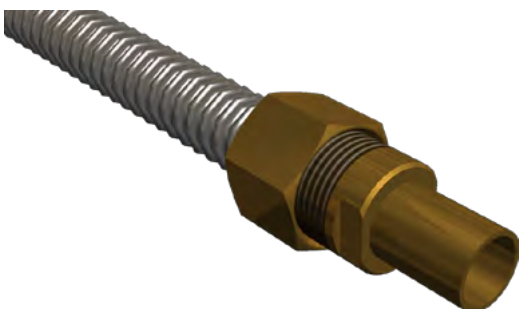

Completely mounted connecting pipe with connector.

Pipe dimension of the connecting pipe

Recommended pipe dimension of the connecting pipe

Length of pipe F + BF Number of collectors	up to 10 m	from 10 m to 15 m	from 15 m to 20 m
	2 coll. - 132 L/h	12 x 1	15 x 1
3 coll. - 198 L/h	15 x 1	15 x 1	15 x 1
4 coll. - 264 L/h	15 x 1	18 x 1	18 x 1
5 coll. - 330 L/h	18 x 1	18 x 1	18 x 1
6 coll. - 396 L/h	18 x 1	18 x 1	22 x 1
7 coll. - 462 L/h	22 x 1	22 x 1	22 x 1
8 coll. - 528 L/h	22 x 1	22 x 1	22 x 1
9 coll. - 594 L/h	22 x 1	22 x 1	22 x 1
10 coll. - 660 L/h	22 x 1	22 x 1	22 x 1
11 coll. - 726 L/h	22 x 1	22 x 1	28 x 1,5
12 coll. - 792 L/h	22 x 1	22 x 1	28 x 1,5
13 coll. - 858 L/h	22 x 1	28 x 1,5	28 x 1,5
14 coll. - 924 L/h	22 x 1	28 x 1,5	28 x 1,5
15 coll. - 990 L/h	22 x 1	28 x 1,5	28 x 1,5

The data refer to the plain tube. With corrugated pipe we recommend to choose the larger dimension!



Length of pipe F + BF Number of collectors	from 20 m to 25 m	from 25 m to 30 m	from 30 m to 35 m	from 35 m to 40 m
	2 coll. - 132 L/h	15 x 1	15 x 1	15 x 1
3 coll. - 198 L/h	18 x 1	18 x 1	18 x 1	18 x 1
4 coll. - 264 L/h	18 x 1	18 x 1	18 x 1	22 x 1
5 coll. - 330 L/h	22 x 1	22 x 1	22 x 1	22 x 1
6 coll. - 396 L/h	22 x 1	22 x 1	22 x 1	22 x 1
7 coll. - 462 L/h	22 x 1	22 x 1	22 x 1	28 x 1,5
8 coll. - 528 L/h	22 x 1	22 x 1	28 x 1,5	28 x 1,5
9 coll. - 594 L/h	22 x 1	28 x 1,5	28 x 1,5	28 x 1,5
10 coll. - 660 L/h	28 x 1,5	28 x 1,5	28 x 1,5	28 x 1,5
11 coll. - 726 L/h	28 x 1,5	28 x 1,5	28 x 1,5	28 x 1,5
12 coll. - 792 L/h	28 x 1,5	28 x 1,5	28 x 1,5	28 x 1,5
13 coll. - 858 L/h	28 x 1,5	28 x 1,5	28 x 1,5	28 x 1,5
14 coll. - 924 L/h	28 x 1,5	28 x 1,5	28 x 1,5	35 x 1,5
15 coll. - 990 L/h	28 x 1,5	28 x 1,5	35 x 1,5	35 x 1,5

The data refer to the plain tube. With corrugated pipe we recommend to choose the larger dimension!



Pipe dimension of the connecting pipe

Recommended pipe dimension of the connecting pipe

Number of collectors	Length of pipe F + BF			
	from 40 m to 45 m	from 45 m to 50 m	from 50 m to 55 m	from 55 m to 60 m
2 coll. - 132 L/h	18 x 1	18 x 1	18 x 1	18 x 1
3 coll. - 198 L/h	18 x 1	18 x 1	18 x 1	22 x 1
4 coll. - 264 L/h	22 x 1	22 x 1	22 x 1	22 x 1
5 coll. - 330 L/h	22 x 1	22 x 1	22 x 1	22 x 1
6 coll. - 396 L/h	22 x 1	22 x 1	22 x 1	22 x 1
7 coll. - 462 L/h	28 x 1,5	28 x 1,5	28 x 1,5	28 x 1,5
8 coll. - 528 L/h	28 x 1,5	28 x 1,5	28 x 1,5	28 x 1,5
9 coll. - 594 L/h	28 x 1,5	28 x 1,5	28 x 1,5	28 x 1,5
10 coll. - 660 L/h	28 x 1,5	28 x 1,5	28 x 1,5	28 x 1,5
11 coll. - 726 L/h	28 x 1,5	28 x 1,5	28 x 1,5	28 x 1,5
12 coll. - 792 L/h	28 x 1,5	35 x 1,5	35 x 1,5	35 x 1,5
13 coll. - 858 L/h	35 x 1,5	35 x 1,5	35 x 1,5	35 x 1,5
14 coll. - 924 L/h	35 x 1,5	35 x 1,5	35 x 1,5	35 x 1,5
15 coll. - 990 L/h	35 x 1,5	35 x 1,5	35 x 1,5	35 x 1,5

The data refer to the plain tube. With corrugated pipe we recommend to choose the larger dimension!



Initial operation

Initial operation

After installing the other components such as flow pipe, return pipe, insulation, pump group, expansion tank and controller the installation can be put into service.

Perform a leak test, fill the system and complete the commissioning log.

Protect the collectors from direct sunlight if the filling of the installation is not carried out within five days after completion of the assembly.

Inspections within the first two weeks of operation

- venting the solar circle
- control system pressure

Instructions for the operation of the installation

Carry out changes to the scheme and other system components only after consultation and with inputs from your specialized partner.

Ensure that an appropriate safety valve is mounted, whose opening pressure is not exceeding the maximal operating pressure of the collectors. Furthermore, do not install shut-off valves that may affect or prevent the function of the safety valve.

Carry out maintenance and inspection with appropriate caution.

Certain components may reach temperatures up to 200° C. There is a risk of burns.

It is absolutely necessary to make sure that the back flow temperature never falls below the ambient temperature. If necessary, take appropriate measures (e.g. increase of back flow temperature to at least 30° C.)

Regular inspections

Solar systems should be reviewed at intervals to be determined in addition to the function control by the operator.

The maintenance intervals of the system will be defined during commissioning.

An annual review is recommended. The following components must be checked for proper function (if installed):

- solar collectors
- solar circle
- heat transfer fluid
- solar storage
- solar regulator incl. circulation pump
- supplementary heating system
- expansion tank

Unscheduled maintenance

Depending on the location of the installation, environmental influences may cause soiling on the collector glass (dust, pollen etc.). Clean the glass, if necessary, exclusively with clear water to ensure optimal light transmission.

If it is necessary to free the system from snow or ice, use only non-metal cleaning equipment, such as brooms, with due care.

Walk on roof areas only in compliance with all safety aspects.

Heavy condensation may occur on the interior side of the glass when defrosting while the collectors are covered with snow. It is absolutely necessary to free the collectors from snow to avoid damages due to humidity.

Initial operation

Commissioning report									
System operator					Installer				
Street					Street				
Postcode/City					Postcode/City				
Material	Product	Type	Special feature	Material	Date of assembly				
tick accordingly	(description)	(Serial N°)	Net surface						
Flat plate collector					Date of commissioning				
Piping									
Heat exchanger					Type of installation				
Storage 1			Content lit.		Roof-integrated				
Storage 2			Content lit.		Roof-mounted				
Solar regulation					Console				
Expansion tank			Content lit.	Safety valve		bar			
DrainMaster			Content lit.						
Collector adjustment south 0°, west +90°; east -90°)					Setting angle of collectors				
Height					Meter				
Setting value (Control value=*)		Type /Programme		Maximum temperature		Temperature difference		Hysteresis	
Consumer 1* = e.g. water for domestic use				°C		VL-RL K		K	
Consumer 2* = e.g. 1. buffer store				°C		K		K	
Consumer 3* = e.g. 2. buffer store				°C		K		K	
Consumer 4* = e.g. swimming pool				°C		K		K	
Maximum temperatur of collector		°C		Solar protective function from °C		Yes		No	
Operating pressure at		bar		System pressure expansion tank		Debit: bar		Actual value:	
Heat transfer medium									
Visual check	normal/pink		brown		black		murky		
Type			Minimum value	Actual value		System		rinsed	
Liquid capacity	pH-value							filtered	
Ratio	Frost protection							bleded	
General system checkpoints									
Collector clean		ok		Pumps tested on functionality				ok	
Stable collector fastening		ok		Temperature sensor shows realistic values				ok	
Collector not steamed up (interior)		ok		Grounding of the system				ok	
Non-return valve (not for DrainM.)		ok		Mixer - water for domestic use				ok	
Operating hours		Pump 1 h		Pump 2 h		Calorimeter /kWh			
Remarks:									

Initial operation

Schematic plan of the system setup and pipework scheme:

Appendix

Important to observe

Any guarantee and warranty for collectors as well as for resulting damages on the system or building expires due to unauthorized changes on the collectors and the accessories.

There is no guarantee or warranty due to optical or technical reduction or defects on the collector resulting from external influences, forasmuch as these influences are not part of the supplier's sphere of influence and they are not explicitly known before execution.

STI Solar-Technologie-International GmbH

Seiferitzer Allee 14
D-08393 Meerane
Tel 0049 3764 795610
info@sti-solar.de

sti-solar.de